

# Customer Services Consumables

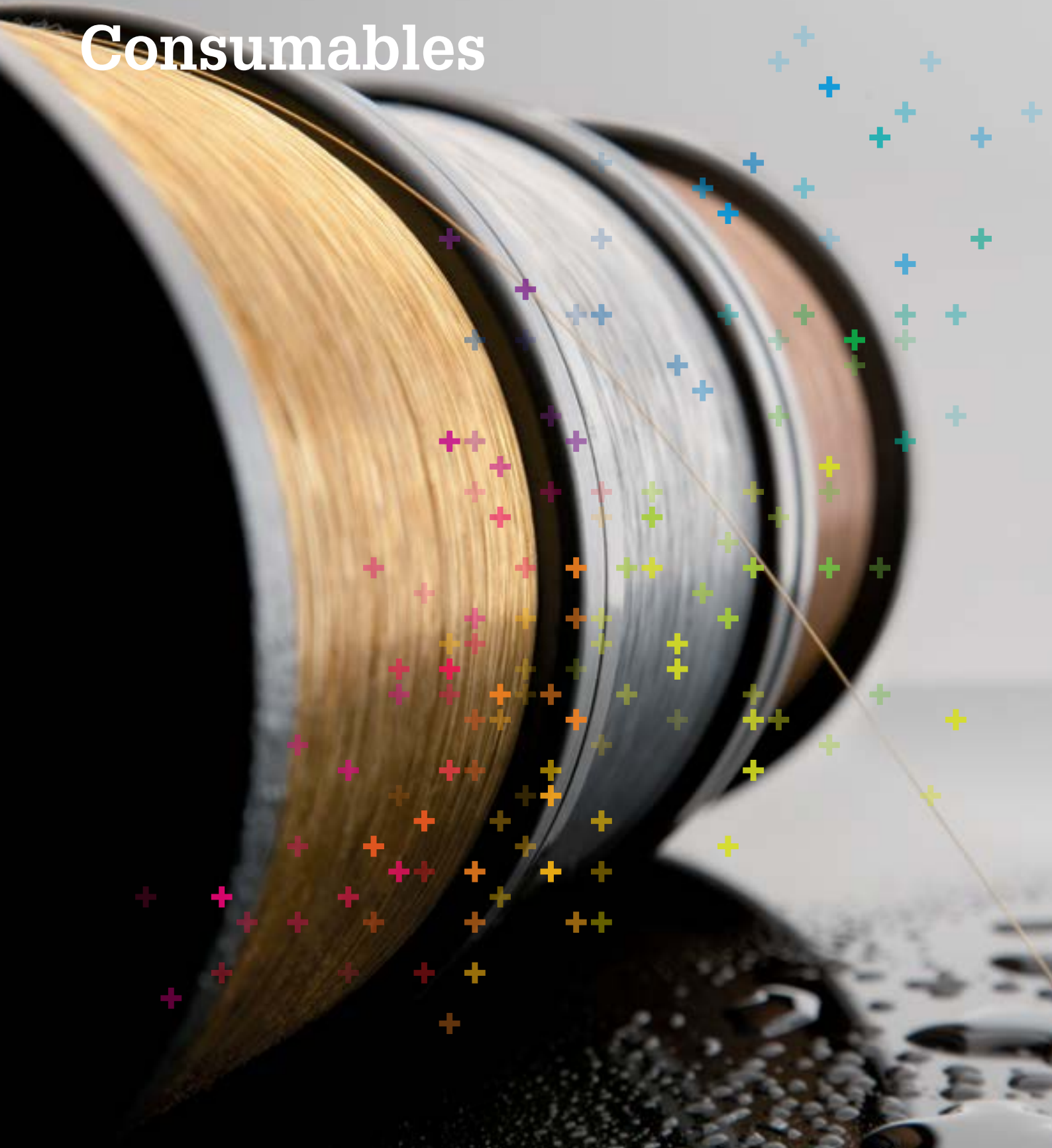





### **Customer Services**



### **Operations Support**

Achieve an optimal performance and level of precision in daily operation



### **Machine Support**

Maximize the operation time of your machines



### **Business Support**

Fully exploit the full potential of your machines

# Consumables

# Content

EDM wires	6
Standard wires	10
Standard wires Compliant product series	34
Fine wires	44
Additional information and reference tables	56
Filters for EDM machines	64
Filters for water	66
Filters for water Compliant product series	70
Filters for oil	74
Deionization systems	76
Dielectrics	84
Graphite electrodes	90
Standard electrodes	92
Saw CUT electrodes	100
Special electrodes	102
Metallic electrodes	104
Drilling electrodes	122
Chemicals and Accessories	156
Information	164



## Consumables

Everything you need for your operations!

This catalog gives you a complete overview of all consumables we offer to run your GF machines at their best. The products in this catalog have been homologated or tested by GF Machining Solutions to ensure you obtain the best results thanks to a perfect synergy between consumables and the distinctive features of GF machines.

The term “consumables” may give a misleading impression of these products, which are often seen as a commodity. In fact this is a big mistake, because the results delivered by a machine are heavily influenced by the quality of the consumables used. Cheaper alternatives may let you save some money in the short term but could cause you many headaches later on. Speculation is very rarely the way to succeed, quality is the safe way of achieving success and GF Consumables are your best choice.

# EDM wires



**Original**

high-end consumables line

**Compliant**

entry-level consumables line

# Content

Standard Wires	
AC Cut A 900	011
AC Cut A 500	013
AC Cut AH 900	014
AC Cut AH 400/500	015
AC Cut G	016
AC Cut GV	017
AC Cut VS 900	018
AC Cut VS 500	020
AC Cut VH	021
AC Cut D 800	022
AC Cut D 500	023
AC Brass 900	024
AC Brass 1000	026
AC Brass 500	027
AC Brass 400	028
AC Brass 950 PF	029
AC Cut X	030
AC Cut XS	031
AC Cut XCC	032
Standard Wires Compliant product series	
AC Cut AL 900	035
AC Cut VL 900	036
AC Cut VL 500	037
AC Brass LP 1000	038
AC Brass LP 900	039
AC Brass LP 500	041
AC Cut XL	042
Fine Wires	
AC Cut Micro A	045
AC Cut Micro SP-Z	046
AC Cut Micro S	047
AC Cut Micro TW	048
AC Cut Micro TWS	049
AC Cut Micro Brass	050
AC Cut A 900	051
AC Cut AH 900	052
AC Brass 900	053
AC Brass 950 PF	054
Additional information and reference tables	
Wire types comparison table	057
Spools technical properties	058
Packaging units	061
Correct wire storage	062
Spool dimensions	063

# Product Overview



## AC Cut A / G

Coated brass wire

AC Cut A 500/900	011
AC Cut AH	014
AC Cut AH 500	015
AC Cut AL 900	035
AC Cut G	016
AC Cut GV	017



## AC Cut V

Coated brass wire

AC Cut D 500/800	022
AC Cut VL 500/900	036
AC Cut VS 500/900	018
AC Cut VH	021



## AC Brass

Brass wire

AC Brass 400/500/900/1000	026
AC Brass 950 PF	054
AC Brass LP 500/900/1000	038



## AC Cut X

Coated copper wire

AC Cut X	030
AC Cut XCC	032
AC Cut XL	042
AC Cut XS	031



## AC Cut Micro

Fine wires

AC Cut Micro A	045
AC Cut Micro Brass	050
AC Cut Micro S	047
AC Cut Micro SP-Z	046
AC Cut Micro TWS	049



# Matrix for a proper wire choice

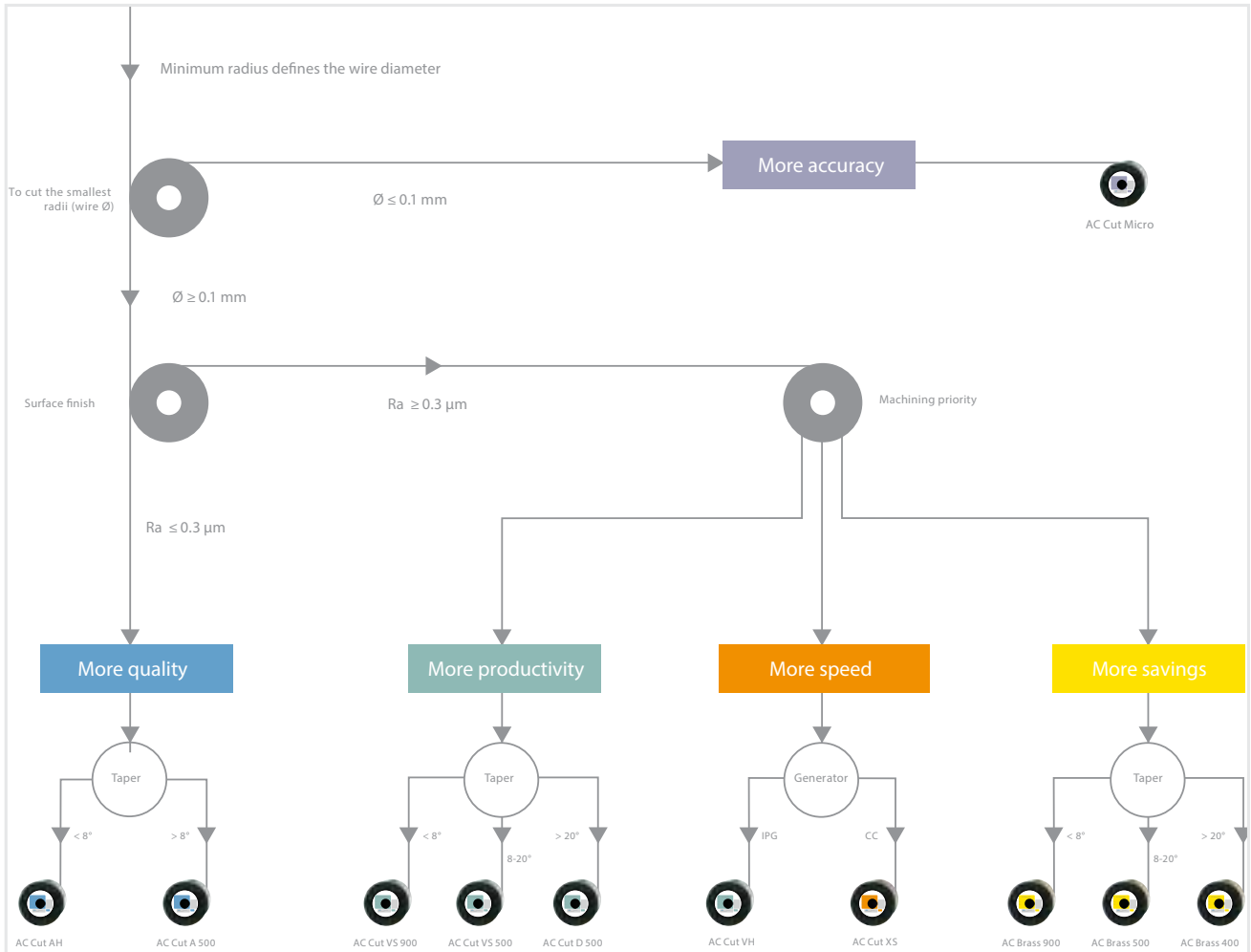

# Standard wires



**Original**

high-end consumables line

# AC Cut A 900

## Precision zinc-coated brass wire



### CHARACTERISTIC

- + AC Cut A 900 is the benchmark wire for very high-quality machining
- + Perfect surface homogeneity and fine surface roughness <math>< Ra 0.1 \mu m</math>
- + Highest precision on geometrical details and part parallelism
- + Recommended for a wide range of applications including molds, cutting tools and general mechanical parts, requiring very high precision and excellent surface finish

### SPECIFICATIONS

Coating: Zinc  
 Conductivity: 22% IACS  
 Elongation: 1%  
 Material: Brass CuZn36/CuZn37  
 Resistance: 900 N/mm<sup>2</sup>

### TECHNICAL DETAILS

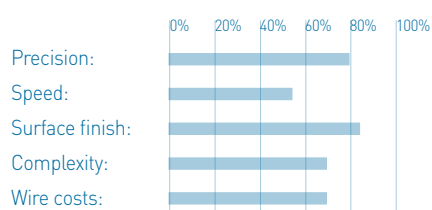

	Reference	Wire diameter (mm)	Resistance (N/mm <sup>2</sup> )	Spool / Package	Spool weight (kg)	Spool type
<b>T</b>	950-101-105	0.15	900	4	4	T125
<b>B</b>	950-101-205	0.15	900	4	4	bedra4
<b>T</b>	950-101-106	0.15	900	2	8	T160
<b>B</b>	950-101-206	0.15	900	2	8	bedra8
<b>B</b>	950-101-210	0.20	900	4	4	bedra4
<b>T</b>	950-101-111	0.20	900	2	8	T160
<b>B</b>	950-101-211	0.20	900	2	8	bedra8
<b>T</b>	950-101-112	0.20	900	1	16	T200
<b>B</b>	950-101-212	0.20	900	1	16	bedra16
<b>B</b>	950-101-213	0.20	900	1	25	K250
<b>B</b>	950-101-218	0.25	900	4	4	bedra4
<b>T</b>	950-101-119	0.25	900	2	8	T160
<b>B</b>	950-101-219	0.25	900	2	8	bedra8
<b>T</b>	950-101-120	0.25	900	1	16	T200
<b>B</b>	950-101-220	0.25	900	1	16	bedra16
<b>T</b>	950-101-121	0.25	900	1	25	K250



### Producer

**T** Thermocompact

**B** Berkenhoff

# AC Cut A 900

Precision zinc-coated brass wire

	Reference	Wire diameter (mm)	Resistance (N/mm <sup>2</sup> )	Spool / Package	Spool weight (kg)	Spool type
<b>B</b>	950-101-221	0.25	900	1	25	K250
<b>T</b>	950-101-127	0.30	900	2	8	T160
<b>T</b>	950-101-128	0.30	900	1	16	K200
<b>B</b>	950-101-228	0.30	900	1	16	bedra16
<b>T</b>	950-101-129	0.30	900	1	25	K250
<b>B</b>	950-101-229	0.30	900	1	25	K250
<b>B</b>	950-101-234	0.33	900	1	16	bedra16



## Producer

**T** Thermocompact

**B** Berkenhoff

# AC Cut A 500

## Precision zinc-coated brass wire



### CHARACTERISTIC

- + AC Cut A 500 is the benchmark wire for high-quality taper machining
- + The technical characteristics of AC Cut A 500 make it possible to achieve very good surface finishes under difficult machining conditions
- + AC Cut A 500 is recommended for high-quality parts that include complex machining with large tapers  $> 8^\circ$

### SPECIFICATIONS

Coating: Zinc

Conductivity: 25% IACS

Elongation: 15%

Material: Brass CuZn37

Resistance: 500 N/mm<sup>2</sup>

### TECHNICAL DETAILS

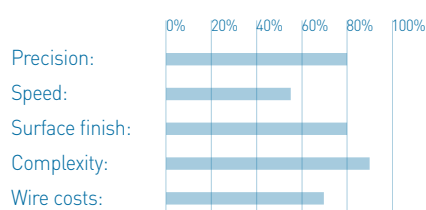

	Reference	Wire diameter (mm)	Resistance (N/mm <sup>2</sup> )	Spool / Package	Spool weight (kg)	Spool type
<b>B</b>	950-102-209	0.15	500	2	8	bedra8
<b>T</b>	950-102-102	0.20	500	2	8	T160
<b>B</b>	950-102-202	0.20	500	2	8	bedra8
<b>B</b>	950-102-203	0.20	500	1	16	bedra16
<b>T</b>	950-102-105	0.25	500	4	4	T125
<b>T</b>	950-102-106	0.25	500	2	8	T160
<b>B</b>	950-102-206	0.25	500	2	8	bedra8
<b>T</b>	950-102-107	0.25	500	1	16	T200
<b>B</b>	950-102-207	0.25	500	1	16	bedra16
<b>T</b>	950-102-108	0.25	500	1	25	K250

### Producer

**T** Thermocompact

**B** Berkenhoff

# AC Cut AH 900

High-performance brass wire coated with special zinc alloy - gamma diffused



## CHARACTERISTIC

- + AC Cut AH is the new generation of A wire which combines perfect surface finish and extremely high productivity
- + Perfect surface homogeneity and very fine surface roughness Ra 0.12 (Water bath) Ra 0.05 µm (Oil bath)
- + Highest precision on geometrical details and part parallelism
- + Combined with the performance of the latest series of generators, it makes it possible to obtain part cost reductions of up to 20%
- + Particularly recommended for top quality punches and dies in steel or carbide

## SPECIFICATIONS

Coating: Special zinc alloy gamma diffused

Conductivity: 21% IACS

Elongation: 1.5%

Material: Brass CuZn37

Resistance: 900 N/mm<sup>2</sup>

## TECHNICAL DETAILS

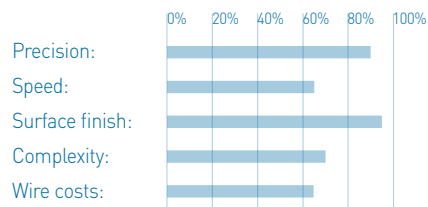

	Reference	Wire diameter (mm)	Resistance (N/mm <sup>2</sup> )	Spool / Package	Spool weight (kg)	Spool type
<b>T</b>	950-100-141	0.15	900	1	4	T125
<b>T</b>	950-100-106	0.15	900	2	8	T160
<b>T</b>	950-100-110	0.20	900	2	8	T160
<b>T</b>	950-100-111	0.20	900	1	16	T200
<b>T</b>	950-100-116	0.25	900	2	8	T160
<b>T</b>	950-100-117	0.25	900	1	16	T200
<b>T</b>	950-100-118	0.25	900	1	25	K250
<b>T</b>	950-100-123	0.30	900	2	8	T160
<b>T</b>	950-100-124	0.30	900	1	16	T200
<b>T</b>	950-100-125	0.30	900	1	25	K250

## Producer

**T** Thermocompact

# AC Cut AH 400/500

High-performance brass wire coated with special zinc alloy - gamma diffused



## CHARACTERISTIC

- + AC Cut AH 400/500 is the new generation of A wire which combines perfect surface finish and productivity with conic machining
- + Very good surface finishes can be achieved under difficult machining conditions thanks to the technical characteristics of AC Cut AH 400/500
- + AC Cut AH 400/500 is recommended for extremely accurate parts which require the machining of complex workpieces with large tapers  $> 8^\circ$

## SPECIFICATIONS

Coating: Special zinc alloy gamma diffused

Conductivity: 21% IACS

Elongation: 20%

Material: Brass CuZn37

Resistance: 400/500 N/mm<sup>2</sup>

## TECHNICAL DETAILS

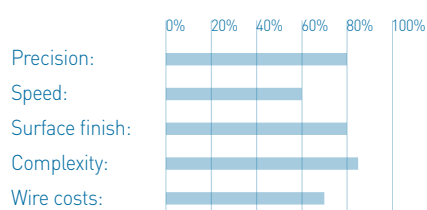

	Reference	Wire diameter (mm)	Resistance (N/mm <sup>2</sup> )	Spool / Package	Spool weight (kg)	Spool type
<b>T</b>	950-110-116	0.25	500	2	8	T160
<b>T</b>	950-111-116	0.25	400	2	8	T160
<b>T</b>	950-110-117	0.25	500	1	16	T200
<b>T</b>	950-111-117	0.25	400	1	16	T200

## Producer

**T** Thermocompact

# AC Cut G

High-performance brass-wire coated with treated zinc



## CHARACTERISTIC

- + AC Cut G is a wire with a brass core
- + This wire was specially developed for AgieCharmilles machines equipped with IPG or earlier generators
- + AC Cut G - machining speeds up to 20% faster than those with brass wire
- + AC Cut G is particularly recommended for standard applications that demand speed and precision

## SPECIFICATIONS

Coating: Zinc treated

Conductivity: 22% IACS

Elongation: 1%

Material: Brass CuZn36

Resistance: 900 N/mm<sup>2</sup>

## TECHNICAL DETAILS

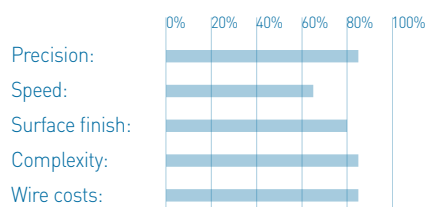

	Reference	Wire diameter (mm)	Resistance (N/mm <sup>2</sup> )	Spool / Package	Spool weight (kg)	Spool type
<b>B</b>	950-103-203	0.15	900	2	8	bedra8
<b>B</b>	950-103-206	0.20	900	2	8	bedra8
<b>B</b>	950-103-207	0.20	900	1	16	bedra16
<b>B</b>	950-103-211	0.25	900	2	8	bedra8
<b>B</b>	950-103-212	0.25	900	1	16	bedra16
<b>B</b>	950-103-213	0.25	900	1	25	K250

## Producer

**B** Berkenhoff



# AC Cut GV\*

High-performance brass-coated wire with special alloy



## CHARACTERISTIC

- + AC Cut GV is the new generation of G wire. A wire that combines surface finish quality and precision with productivity
- + Perfect surface homogeneity and very fine surface roughness Ra 0.12 µm (Water bath) and Ra 0.05 µm (Oil bath)
- + Highest precision on geometrical details and part parallelis
- + 100% compatible with AC Cut A 900 and AC Cut G technologies
- + AC Cut GV is recommended for top quality parts including punches and dies in steel or carbide
- + AC Cut GV - machining speeds are up to 10% faster than those with brass wire

## SPECIFICATIONS

Coating: Special layer

Conductivity: 22% IACS

Elongation: 1%

Material: Brass CuZn36

Resistance: 900 N/mm<sup>2</sup>

## TECHNICAL DETAILS

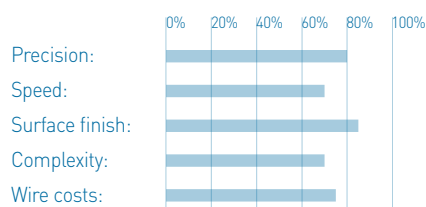

	Reference	Wire diameter (mm)	Resistance (N/mm <sup>2</sup> )	Spool / Package	Spool weight (kg)	Spool type
<b>B</b>	950-112-206	0.20	900	2	8	bedra8
<b>B</b>	950-112-207	0.20	900	1	16	bedra16
<b>B</b>	950-112-211	0.25	900	2	8	bedra8
<b>B</b>	950-112-212	0.25	900	1	16	bedra16
<b>B</b>	950-112-213	0.25	900	1	25	K250

## Producer

**B** Berkenhoff

\*Approval process underway

# AC Cut VS 900

High-performance brass wire coated with gamma diffused zinc



## CHARACTERISTIC

- + AC Cut VS 900 is the latest generation of brass-coated wire that combines productivity and part cost reduction
- + Production of parts is increased by up to 25% compared to standard brass wire (valid also for brass wire technology)
- + Part cost reduced by up to 20% compared to standard brass wire
- + AC Cut VS 900 is the optimal answer to the needs of most mold, punch and general mechanical applications that require precision and productivity

## SPECIFICATIONS

Coating: Zinc gamma diffused

Conductivity: 20% IACS

Elongation: 2%

Material: Brass CuZn37

Resistance: 900 N/mm<sup>2</sup>

## TECHNICAL DETAILS

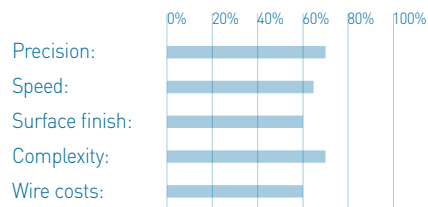

	Reference	Wire diameter (mm)	Resistance (N/mm <sup>2</sup> )	Spool / Package	Spool weight (kg)	Spool type
<b>T</b>	950-203-101	0.20	900	2	8	T160
<b>B</b>	950-203-201	0.20	900	2	8	bedra8
<b>T</b>	950-203-102	0.20	900	1	16	T200
<b>B</b>	950-203-202	0.20	900	1	16	bedra16
<b>B</b>	950-203-221	0.20	900	1	25	K250
<b>T</b>	950-203-106	0.25	900	4	4	T125
<b>T</b>	950-203-107	0.25	900	2	8	T160
<b>B</b>	950-203-207	0.25	900	2	8	bedra8
<b>T</b>	950-203-108	0.25	900	1	16	T200
<b>B</b>	950-203-208	0.25	900	1	16	bedra16
<b>T</b>	950-203-109	0.25	900	1	25	K250
<b>B</b>	950-203-209	0.25	900	1	25	K250
<b>T</b>	950-203-110	0.25	900	4	5	P5
<b>T</b>	950-203-111	0.25	900	2	10	P10
<b>T</b>	950-203-112	0.25	900	1	20	P15
<b>B</b>	950-203-212	0.25	900	1	20	P15



## Producer

**T** Thermocompact

**B** Berkenhoff

# AC Cut VS 900

High-performance brass wire coated with gamma diffused zinc

	Reference	Wire diameter (mm)	Resistance (N/mm <sup>2</sup> )	Spool / Package	Spool weight (kg)	Spool type
<b>T</b>	950-203-113	0.30	900	4	4	T125
<b>T</b>	950-203-114	0.30	900	2	8	T160
<b>T</b>	950-203-115	0.30	900	1	16	T200
<b>B</b>	950-203-215	0.30	900	1	16	bedra16
<b>T</b>	950-203-116	0.30	900	1	25	K250
<b>B</b>	950-203-216	0.30	900	1	25	K250
<b>T</b>	950-203-117	0.30	900	1	45	K355
<b>B</b>	950-203-217	0.30	900	1	45	K355
<b>T</b>	950-203-119	0.30	900	2	10	P10
<b>B</b>	950-203-219	0.30	900	2	10	P10
<b>T</b>	950-203-120	0.30	900	1	20	P15
<b>T</b>	950-203-122	0.33	900	1	25	K250
<b>B</b>	950-203-222	0.33	900	1	25	K250



## Producer

**T** Thermocompact

**B** Berkenhoff

# AC Cut VS 500

High-performance brass wire coated with gamma diffused zinc



## CHARACTERISTIC

- + AC Cut VS 500 is the latest generation of zinc-coated brass wire which combines productivity and part cost reduction for conic machining
- + The best alternative to soft brass wire
- + AC Cut VS 500 is recommended for complex machining with large tapers  $> 8^\circ$  that require precision and productivity

## SPECIFICATIONS

Coating: Zinc gamma diffused

Conductivity: 24% IACS

Elongation: 11%

Material: Brass CuZn37

Resistance: 500 N/mm<sup>2</sup>

## TECHNICAL DETAILS

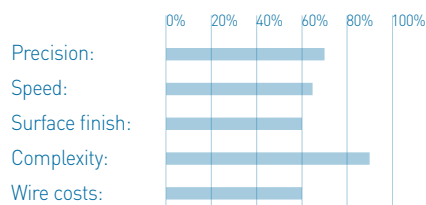

	Reference	Wire diameter (mm)	Resistance (N/mm <sup>2</sup> )	Spool / Package	Spool weight (kg)	Spool type
<b>B</b>	950-204-201	0.20	500	2	8	bedra8
<b>T</b>	950-204-102	0.20	500	1	16	T200
<b>B</b>	950-204-202	0.20	500	1	16	bedra16
<b>T</b>	950-204-104	0.20	500	2	10	P10
<b>B</b>	950-204-204	0.20	500	1	10	P10
<b>T</b>	950-204-105	0.20	500	1	20	P15
<b>B</b>	950-204-205	0.20	500	1	20	P15
<b>B</b>	950-204-206	0.25	500	4	4	bedra4
<b>T</b>	950-204-107	0.25	500	2	8	T160
<b>B</b>	950-204-207	0.25	500	2	8	bedra8
<b>T</b>	950-204-108	0.25	500	1	16	T200
<b>B</b>	950-204-208	0.25	500	1	16	bedra16
<b>B</b>	950-204-210	0.25	500	4	5	P5
<b>B</b>	950-204-215	0.30	500	1	16	bedra16

## Producer

**T** Thermocompact

**B** Berkenhoff

# AC Cut VH

Brass wire coated with a double layer of zinc gamma diffused



## CHARACTERISTIC

- + AC Cut VH is a new generation of economical wire which is the best alternative to AC Cut D 800 and offers higher performance at lower cost
- + AC Cut VH is made from a brass alloy with only 20% zinc combining excellent machining efficiency and part cost reduction
- + This wire is intended for GF AgieCharmilles machines equipped with an IPG generator
- + AC Cut VH is the best compromise for fast delivery at a reasonable cost
- + Up to 30% faster compared to standard brass wire

## SPECIFICATIONS

Coating: Double layer of zinc gamma diffused

Conductivity: 28% IACS

Elongation: 2%

Material: Brass CuZn20

Resistance: 900 N/mm<sup>2</sup>

## TECHNICAL DETAILS

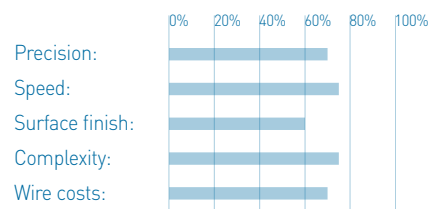

	Reference	Wire diameter (mm)	Resistance (N/mm <sup>2</sup> )	Spool / Package	Spool weight (kg)	Spool type
<b>T</b>	950-202-101	0.20	900	2	8	T160
<b>T</b>	950-202-102	0.20	900	1	16	T200
<b>T</b>	950-202-106	0.25	900	2	8	T160
<b>T</b>	950-202-107	0.25	900	1	16	T200
<b>T</b>	950-202-108	0.25	900	1	25	K250
<b>B</b>	950-202-207	0.25	900	1	16	bedra16
<b>T</b>	950-202-110	0.25	900	2	10	P10
<b>T</b>	950-202-112	0.30	900	2	8	T160
<b>T</b>	950-202-113	0.30	900	1	16	T200
<b>T</b>	950-202-114	0.30	900	1	25	K250
<b>T</b>	950-202-117	0.30	900	1	20	P15
<b>T</b>	950-202-120	0.33	900	1	25	K250

## Producer

**T** Thermocompact

**B** Berkenhoff

# AC Cut D 800

High-performance brass wire coated with diffused zinc



## CHARACTERISTIC

- + AC Cut D 800 is a brass-core wire made with only 20% zinc which allows high energy for good speed performance
- + This wire is intended for AgieCharmilles machines equipped with an IPG or previous-generation generator
- + AC Cut D 800 enables machining speeds up to 20% faster than a brass wire
- + AC Cut D 800 is particularly recommended for standard applications that require speed and precision

## SPECIFICATIONS

Coating: CuZn50, Zinc diffused

Conductivity: 27% IACS

Elongation: 2%

Material: Brass CuZn20

Resistance: 800 N/mm<sup>2</sup>

## TECHNICAL DETAILS

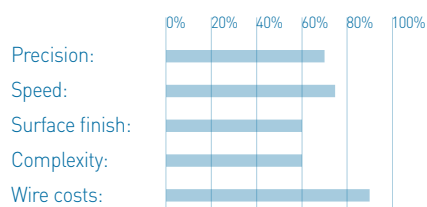

	Reference	Wire diameter (mm)	Resistance (N/mm <sup>2</sup> )	Spool / Package	Spool weight (kg)	Spool type
<b>B</b>	950-201-202	0.20	800	1	16	bedra16
<b>T</b>	950-201-103	0.25	800	2	8	T160
<b>B</b>	950-201-203	0.25	800	2	8	bedra8
<b>T</b>	950-201-104	0.25	800	1	16	T200
<b>B</b>	950-201-204	0.25	800	1	16	bedra16
<b>B</b>	950-201-205	0.25	800	1	25	K250
<b>B</b>	950-201-206	0.25	800	1	45	K355
<b>T</b>	950-201-108	0.30	800	1	16	T200
<b>B</b>	950-201-208	0.30	800	1	16	bedra16
<b>B</b>	950-201-209	0.30	800	1	25	K250
<b>B</b>	950-201-210	0.30	800	1	45	K355

## Producer

**T** Thermocompact

**B** Berkenhoff

# AC Cut D 500

High-performance brass wire coated for large tapers, with diffused zinc



## CHARACTERISTIC

- + AC Cut D 500 is a brass-core wire made with only 20% zinc which allows excellent performance for conic machining
- + This wire is intended for AgieCharmilles machines equipped with an IPG or previous-generation generator
- + AC Cut D 500 enables a machining speed up to 20% faster than a brass wire
- + AC Cut D 500 is particularly recommended for complex machining with large tapers > 8°

## SPECIFICATIONS

Coating: CuZn50, Zinc diffused

Conductivity: 31% IACS

Elongation: 30%

Material: Brass CuZn20

Resistance: 500 N/mm<sup>2</sup>

## TECHNICAL DETAILS

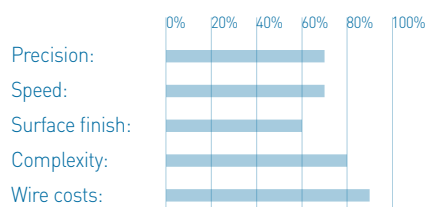

	Reference	Wire diameter (mm)	Resistance (N/mm <sup>2</sup> )	Spool / Package	Spool weight (kg)	Spool type
<b>B</b>	950-200-201	0.20	500	2	8	bedra8
<b>T</b>	950-200-102	0.25	500	2	8	T160
<b>B</b>	950-200-202	0.25	500	2	8	bedra8
<b>T</b>	950-200-103	0.25	500	1	16	T200
<b>B</b>	950-200-203	0.25	500	1	16	bedra16

## Producer

**T** Thermocompact

**B** Berkenhoff

# AC Brass 900

High-quality brass wire



## CHARACTERISTIC

- + AC Brass 900 is made from a very pure alloy in order to guarantee consistent quality and performance for universal machining
- + Multipurpose wire
- + Suitable for all commercially available machines
- + AC Brass 900 is recommended for standard applications

## SPECIFICATIONS

Coating: Not coated

Conductivity: 22% IACS

Elongation: 1.5%

Material: Brass CuZn37

Resistance: 900 N/mm<sup>2</sup>

## TECHNICAL DETAILS

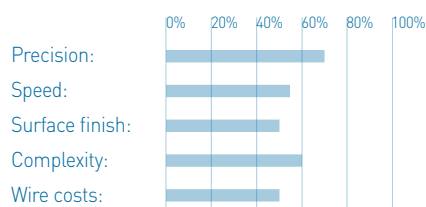

	Reference	Wire diameter (mm)	Resistance (N/mm <sup>2</sup> )	Spool / Package	Spool weight (kg)	Spool type
<b>T</b>	950-302-103	0.15	900	4	4	K125
<b>T</b>	950-302-104	0.15	900	2	8	K160
<b>B</b>	950-302-204	0.15	900	2	8	bedra8
<b>T</b>	950-302-106	0.20	900	4	4	K125
<b>T</b>	950-302-107	0.20	900	2	8	K160
<b>B</b>	950-302-207	0.20	900	2	8	bedra8
<b>T</b>	950-302-108	0.20	900	1	16	K200
<b>B</b>	950-302-208	0.20	900	1	16	bedra16
<b>B</b>	950-302-209	0.20	900	1	25	K250
<b>T</b>	950-302-111	0.20	900	4	5	P5
<b>T</b>	950-302-112	0.20	900	2	10	P10
<b>B</b>	950-302-212	0.20	900	2	10	P10
<b>T</b>	950-302-115	0.25	900	4	4	K125
<b>B</b>	950-302-215	0.25	900	4	4	bedra4
<b>T</b>	950-302-116	0.25	900	2	8	K160
<b>B</b>	950-302-216	0.25	900	2	8	bedra8



## Producer

**T** Thermocompact

**B** Berkenhoff



# AC Brass 900

High-quality brass wire

	Reference	Wire diameter (mm)	Resistance (N/mm <sup>2</sup> )	Spool / Package	Spool weight (kg)	Spool type
<b>T</b>	950-302-117	0.25	900	1	16	K200
<b>B</b>	950-302-217	0.25	900	1	16	bedra16
<b>T</b>	950-302-118	0.25	900	1	25	K250
<b>B</b>	950-302-218	0.25	900	1	25	K250
<b>T</b>	950-302-119	0.25	900	1	45	K355
<b>B</b>	950-302-219	0.25	900	1	45	K355
<b>T</b>	950-302-120	0.25	900	4	5	P5
<b>T</b>	950-302-121	0.25	900	2	10	P10
<b>T</b>	950-302-125	0.30	900	2	8	K160
<b>B</b>	950-302-225	0.30	900	2	8	bedra8
<b>T</b>	950-302-126	0.30	900	1	16	K200
<b>B</b>	950-302-226	0.30	900	1	16	bedra16
<b>T</b>	950-302-127	0.30	900	1	25	K250
<b>B</b>	950-302-227	0.30	900	1	25	K250
<b>B</b>	950-302-230	0.30	900	2	10	P10



## Producer

**T** Thermocompact

**B** Berkenhoff

# AC Brass 1000

High-quality brass wire

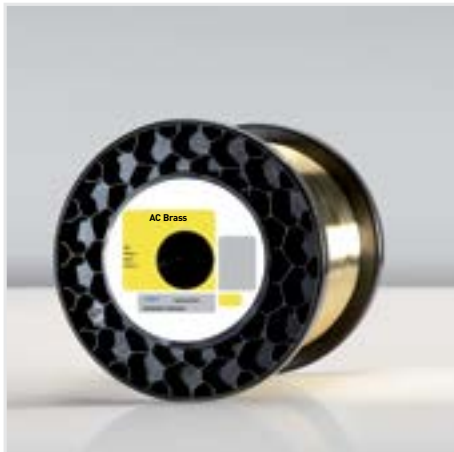

## CHARACTERISTIC

- + AC Brass 1000 is a high-quality wire made from a very pure alloy in order to guarantee consistent quality and performance to meet exacting requirements
- + Special processes are used to manufacture this wire in order to increase its straightness
- + Suitable for all commercially available machines
- + AC Brass 1000 is recommended for standard applications that require precision and surface quality
- + Low-paraffin

## SPECIFICATIONS

Coating: Not coated

Conductivity: 22% IACS

Elongation: 1.5%

Material: Brass CuZn40

Resistance: 1000 N/mm<sup>2</sup>

## TECHNICAL DETAILS

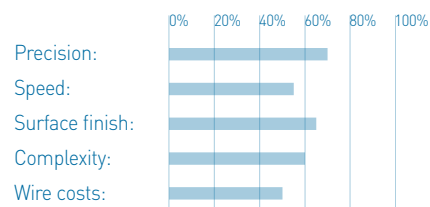

	Reference	Wire diameter (mm)	Resistance (N/mm <sup>2</sup> )	Spool / Package	Spool weight (kg)	Spool type
<b>T</b>	950-306-110	0.25	1000	2	8	K160
<b>T</b>	950-306-125	0.30	1000	2	8	K160

## Producer

**T** Thermocompact

# AC Brass 500

High-quality brass wire

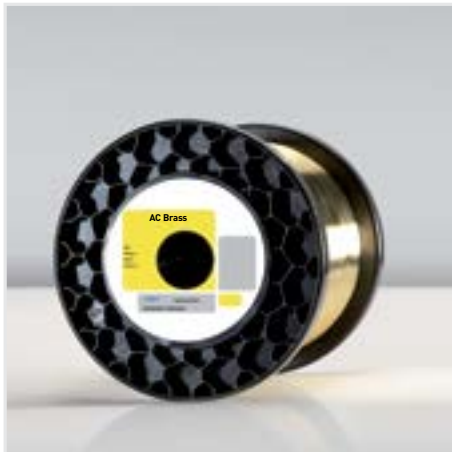

## CHARACTERISTIC

- + AC Brass 500 is made from a very pure alloy in order to guarantee consistent quality and performance for conic machining
- + Suitable for all commercially available machines
- + AC Brass 500 is particularly recommended for standard applications with large tapers > 8°

## SPECIFICATIONS

Coating: Not coated

Conductivity: 25% IACS

Elongation: 20%

Material: Brass CuZn37

Resistance: 500 N/mm<sup>2</sup>

## TECHNICAL DETAILS

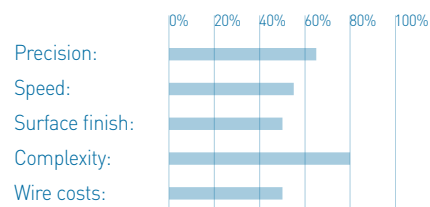

	Reference	Wire diameter (mm)	Resistance (N/mm <sup>2</sup> )	Spool / Package	Spool weight (kg)	Spool type
<b>T</b>	950-301-106	0.20	500	4	4	K125
<b>T</b>	950-301-107	0.20	500	2	8	K160
<b>T</b>	950-301-115	0.25	500	4	4	K125
<b>B</b>	950-301-215	0.25	500	4	4	bedra4
<b>T</b>	950-301-116	0.25	500	2	8	K160
<b>B</b>	950-301-216	0.25	500	2	8	bedra8
<b>T</b>	950-301-117	0.25	500	1	16	K200
<b>B</b>	950-301-217	0.25	500	1	16	bedra16
<b>T</b>	950-301-118	0.25	500	1	25	K250
<b>B</b>	950-301-218	0.25	500	1	25	K250
<b>T</b>	950-301-124	0.30	500	4	4	K125
<b>T</b>	950-301-125	0.30	500	2	8	K160
<b>T</b>	950-301-126	0.30	500	1	16	K200
<b>B</b>	950-301-226	0.30	500	1	16	bedra16

## Producer

**T** Thermocompact

**B** Berkenhoff

# AC Brass 400

High-quality brass wire

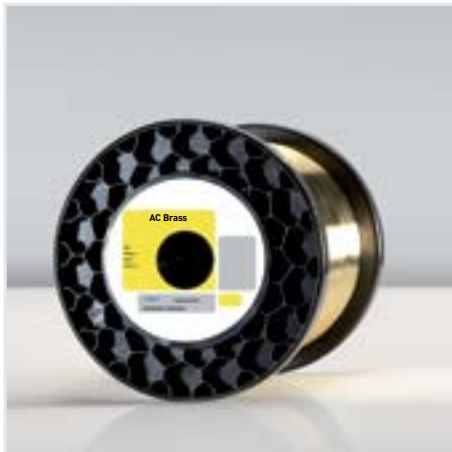

## CHARACTERISTIC

- + AC Brass 400 is made from a very pure alloy in order to guarantee consistent quality and performance for demanding conic machining
- + AC Brass 400 is particularly recommended for standard applications with very large tapers (>15°)

## SPECIFICATIONS

Coating: Not coated  
 Conductivity: 26% IACS  
 Elongation: 25%  
 Material: Brass CuZn37  
 Resistance: 400 N/mm<sup>2</sup>

## TECHNICAL DETAILS

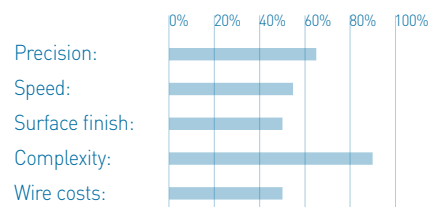

	Reference	Wire diameter (mm)	Resistance (N/mm <sup>2</sup> )	Spool / Package	Spool weight (kg)	Spool type
<b>T</b>	950-300-106	0.20	400	4	4	K125
<b>T</b>	950-300-115	0.25	400	4	4	K125
<b>B</b>	950-300-215	0.25	400	4	4	bedra4
<b>T</b>	950-300-116	0.25	400	2	8	K160
<b>B</b>	950-300-216	0.25	400	2	8	bedra8
<b>T</b>	950-300-117	0.25	400	1	16	K200
<b>T</b>	950-300-126	0.30	400	1	16	K200

## Producer

**T** Thermocompact

**B** Berkenhoff

# AC Brass 950 PF\*

High-quality brass wire

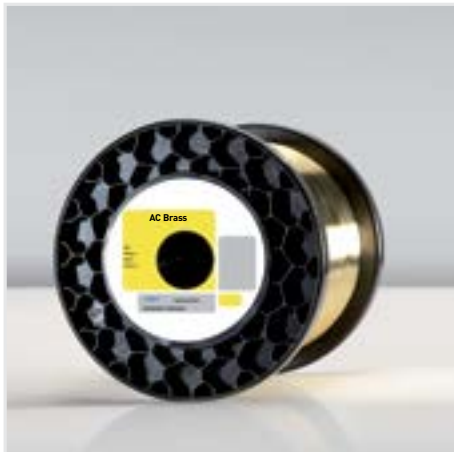

## CHARACTERISTIC

- + AC Brass 950 PF is a high-quality wire made from a very pure alloy in order to guarantee consistent quality and performance for high-end machining
- + Special processes are used to manufacture this wire in order to increase its straightness
- + Suitable for all commercially available machines
- + Particularly recommended for Fanuc and Mitsubishi machines
- + AC Brass 950 PF is recommended for standard applications that require high precision and good surface quality
- + Paraffin-free

## SPECIFICATIONS

Coating: Not coated

Conductivity: 22% IACS

Elongation: 1.5%

Material: Brass CuZn37

Resistance: 950 N/mm<sup>2</sup>

## TECHNICAL DETAILS

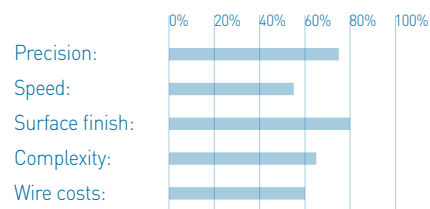

	Reference	Wire diameter (mm)	Resistance (N/mm <sup>2</sup> )	Spool / Package	Spool weight (kg)	Spool type
	950-305-504	0.20	950	2	8	K160
	950-305-506	0.20	950	4	5	P5
	950-305-505	0.20	950	1	15	P10
	950-305-507	0.20	950	2	10	P10
	950-305-510	0.25	950	2	8	K160
	950-305-511	0.25	950	1	15	P10
	950-305-514	0.25	950	2	10	P10
	950-305-515	0.25	950	1	20	P15

## Producer



Ok

\*Approval process underway

# AC Cut X

Copper-core coated wire with zinc diffused

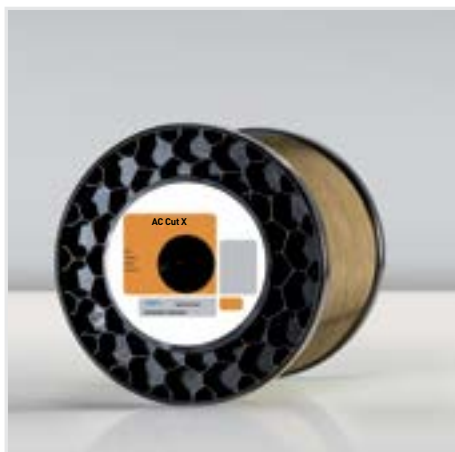

## CHARACTERISTIC

- + AC Cut X is the benchmark wire for high-speed wires
- + AC Cut X is up to 20% faster than standard brass wire
- + This wire was specially developed and is designed for AgieCharmilles machines (formerly CT)
- + AC Cut X reduces production costs in a wide variety of complex applications

## SPECIFICATIONS

Coating: Zinc diffused  
 Conductivity: 80% IACS  
 Elongation: 1%  
 Material: Copper (Cu)  
 Resistance: 450 - 520 N/mm<sup>2</sup>

## TECHNICAL DETAILS

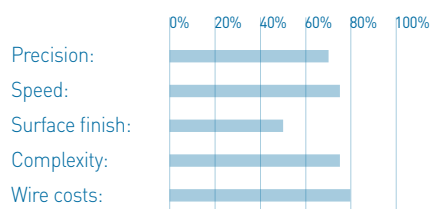

	Reference	Wire diameter (mm)	Resistance (N/mm <sup>2</sup> )	Spool / Package	Spool weight (kg)	Spool type
<b>T</b>	950-002-100	0.25	450	4	4	T125
<b>B</b>	950-002-200	0.25	520	4	4	bedra4
<b>T</b>	950-002-101	0.25	450	2	8	T160
<b>B</b>	950-002-201	0.25	520	2	8	bedra8
<b>T</b>	950-002-102	0.25	450	1	16	T200
<b>B</b>	950-002-202	0.25	520	1	16	bedra16
<b>T</b>	950-002-103	0.25	450	1	25	K250
<b>B</b>	950-002-203	0.25	520	1	25	K250
<b>B</b>	950-002-216	0.25	520	1	25	P15
<b>T</b>	950-002-109	0.30	450	2	8	T160
<b>B</b>	950-002-209	0.30	520	2	8	bedra8
<b>T</b>	950-002-110	0.30	450	1	16	T200
<b>B</b>	950-002-210	0.30	520	1	16	bedra16
<b>T</b>	950-002-111	0.30	450	1	25	K250
<b>B</b>	950-002-211	0.30	520	1	25	K250
<b>B</b>	950-002-212	0.30	520	1	45	K355

## Producer

**T** Thermocompact

**B** Berkenhoff

# AC Cut XS

Copper-core coated wire with a double layer of zinc gamma diffused



## CHARACTERISTIC

- + AC Cut XS is a new generation of X wire that combines speed and precision with the best price/performance ratio
- + AC Cut XS is up to 30% faster than a standard brass wire
- + 100% compatible with AC Cut X technologies
- + AC Cut XS is the best compromise for fast delivery at a reasonable cost

## SPECIFICATIONS

Coating: Double layer of zinc gamma diffused

Conductivity: 70% IACS

Elongation: 1%

Material: Copper (Cu)

Resistance: 450 - 500 N/mm<sup>2</sup>

## TECHNICAL DETAILS

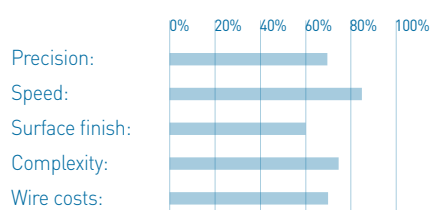

	Reference	Wire diameter (mm)	Resistance (N/mm <sup>2</sup> )	Spool / Package	Spool weight (kg)	Spool type
<b>T</b>	950-001-100	0.25	450	4	4	T125
<b>T</b>	950-001-101	0.25	450	2	8	T160
<b>B</b>	950-001-201	0.25	500	2	8	bedra8
<b>T</b>	950-001-102	0.25	450	1	16	T200
<b>B</b>	950-001-202	0.25	500	1	16	bedra16
<b>T</b>	950-001-103	0.25	450	1	25	K250
<b>B</b>	950-001-203	0.25	500	1	25	K250
<b>T</b>	950-001-108	0.30	450	4	4	T125
<b>T</b>	950-001-109	0.30	450	2	8	T160
<b>T</b>	950-001-110	0.30	450	1	16	T200
<b>B</b>	950-001-210	0.30	500	1	16	bedra16
<b>T</b>	950-001-111	0.30	450	1	25	K250

## Producer

**T** Thermocompact

**B** Berkenhoff

# AC Cut XCC

Copper-core coated wire coated with a thick layer of zinc diffused

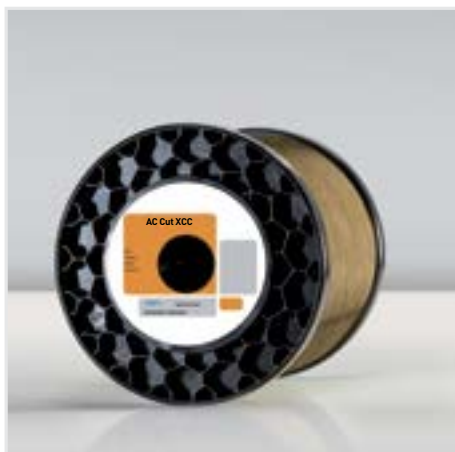

## CHARACTERISTIC

- + This wire was specially developed for AgieChamilles machines to boost machining speed
- + When used with a machine equipped with a CC generator, a cutting speed of more than 500 mm<sup>2</sup>/min can be achieved
- + Particularly recommended for machining mechanical applications by units or in series and for tall parts
- + AC Cut XCC is the optimal solution when machining speed is the priority

## SPECIFICATIONS

Coating: Thick layer of zinc diffused

Conductivity: 65% IACS

Elongation: 2%

Material: Copper (Cu)

Resistance: 500 N/mm<sup>2</sup>

## TECHNICAL DETAILS

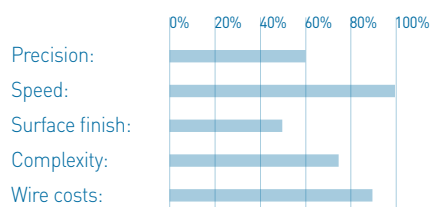

	Reference	Wire diameter (mm)	Resistance (N/mm <sup>2</sup> )	Spool / Package	Spool weight (kg)	Spool type
<b>T</b>	950-000-100	0.25	500	2	8	T160
<b>T</b>	950-000-101	0.25	500	1	16	T200
<b>T</b>	950-000-102	0.25	500	1	25	K250
<b>T</b>	950-000-104	0.30	500	2	8	T160
<b>T</b>	950-000-105	0.30	500	1	16	T200
<b>T</b>	950-000-108	0.33	500	2	8	T160
<b>T</b>	950-000-109	0.33	500	1	16	T200
<b>T</b>	950-000-110	0.33	500	1	25	K250

## Producer

**T** Thermocompact





# Standard wires Compliant product series



**Compliant**

entry-level consumables line

# AC Cut AL 900

High-performance zinc-coated brass wire



## CHARACTERISTIC

- + AC Cut AL 900 is a high-performance zinc-coated brass wire using an economical manufacturing process which makes it very competitive
- + Perfect surface quality and highest precision
- + 100% compatible with AC Cut A 900 technologies
- + AC Cut AL 900 is recommended for a wide range of standard applications including molds, cutting tools and general mechanical work that require high precision and fine surface finishes

## SPECIFICATIONS

Coating: Zinc

Conductivity: 22% IACS

Elongation: 1.5%

Material: Brass CuZn37

Resistance: 900 N/mm<sup>2</sup>

## TECHNICAL DETAILS

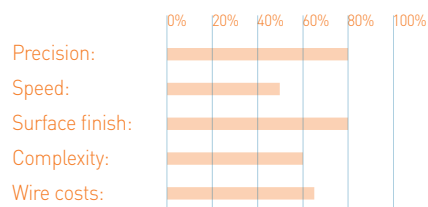

	Reference	Wire diameter (mm)	Resistance (N/mm <sup>2</sup> )	Spool / Package	Spool weight (kg)	Spool type
<b>T</b>	950-104-101	0.20	900	1	16	T200
<b>T</b>	950-104-105	0.25	900	2	8	T160
<b>TV</b>	950-104-405	0.25	900	2	8	K160
<b>T</b>	950-104-106	0.25	900	1	16	T200
<b>B</b>	950-104-206	0.25	900	1	16	K200
<b>TV</b>	950-104-406	0.25	900	1	16	K200
<b>T</b>	950-104-107	0.25	900	1	25	K250
<b>TV</b>	950-104-407	0.25	900	1	25	K250
<b>T</b>	950-104-112	0.30	900	1	16	T200
<b>B</b>	950-104-212	0.30	900	1	16	K200
<b>T</b>	950-104-114	0.30	900	1	45	K355

## Producer

**T** Thermocompact

**B** Berkenhoff

**TV** Thermocompact (VN)

# AC Cut VL 900

Brass-coated wire with zinc gamma diffused



## CHARACTERISTIC

- + AC Cut VL 900 is the latest generation of zinc-coated brass wire specifically intended for standard machining. It uses an economical manufacturing process which makes it very competitive
- + Increased production of parts by up to 25% and reduced part cost compared to standard brass wire (valid also for brass wire technology)
- + AC Cut VL 900 is the best compromise for meeting the needs of most standard applications that require productivity at the best price

## SPECIFICATIONS

Coating: Zinc gamma diffused

Conductivity: 20% IACS

Elongation: 2%

Material: Brass CuZn37

Resistance: 900 N/mm<sup>2</sup>

## TECHNICAL DETAILS

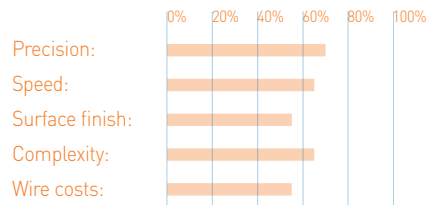

	Reference	Wire diameter (mm)	Resistance (N/mm <sup>2</sup> )	Spool / Package	Spool weight (kg)	Spool type
<b>TV</b>	950-205-407	0.25	900	2	8	K160
<b>TV</b>	950-205-408	0.25	900	1	16	K200
<b>TV</b>	950-205-410	0.25	900	4	5	P5

## Producer

**TV** Thermocompact (VN)

# AC Cut VL 500

Brass-coated wire with zinc gamma diffused



## CHARACTERISTIC

- + AC Cut VL 500 is the latest generation of zinc-coated brass wire specifically intended for conic machining. It uses an economical manufacturing process which makes it very competitive
- + Increased production of parts and reduced part cost compared to standard soft brass wire
- + AC Cut VL 500 is recommended for complex machining with large tapers  $> 8^\circ$  which require productivity

## SPECIFICATIONS

Coating: Zinc Gamma diffused

Conductivity: 24% IACS

Elongation: 11%

Material: Brass CuZn37

Resistance: 500 N/mm<sup>2</sup>

## TECHNICAL DETAILS

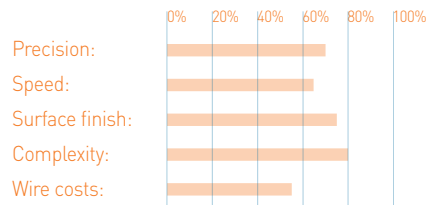

	Reference	Wire diameter (mm)	Resistance (N/mm <sup>2</sup> )	Spool / Package	Spool weight (kg)	Spool type
<b>TV</b>	950-206-407	0.25	500	2	8	K160

## Producer

**TV** Thermocompact (VN)

# AC Brass LP 1000

Brass wire

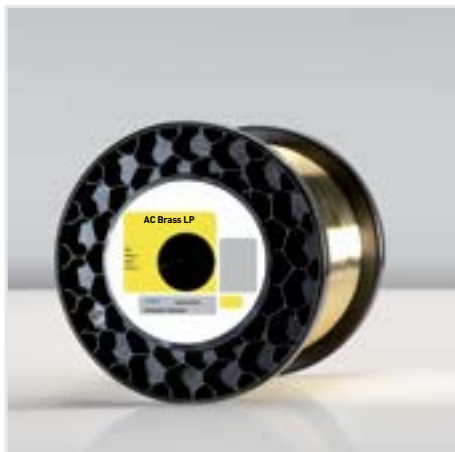

## CHARACTERISTIC

- + AC Brass LP 1000 is made from a pure alloy, using an economical manufacturing process which makes it very competitive for universal machining
- + Multipurpose wire, price oriented
- + Suitable for all commercially available machines
- + AC Brass LP 1000 is recommended for standard applications

## SPECIFICATIONS

Coating: Not coated

Conductivity: 22% IACS

Elongation: 1.5%

Material: Brass CuZn37

Resistance: 900 N/mm<sup>2</sup>

## TECHNICAL DETAILS

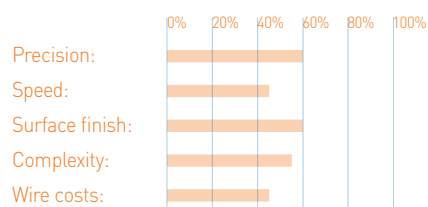

	Reference	Wire diameter (mm)	Resistance (N/mm <sup>2</sup> )	Spool / Package	Spool weight (kg)	Spool type
<b>KQ</b>	950-309-616	0.25	1000	2	8	K160
<b>KQ</b>	950-309-617	0.25	1000	1	16	K200

## Producer



# AC Brass LP 900

## Brass wire

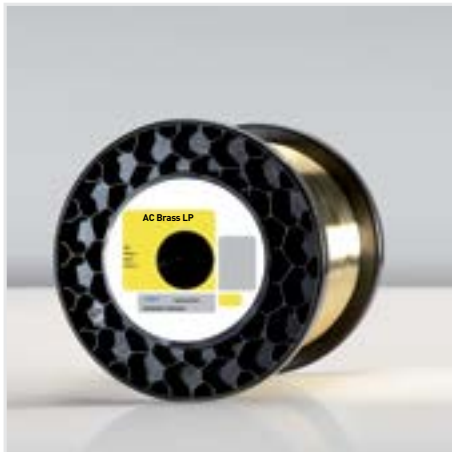

### CHARACTERISTIC

- + AC Brass LP 900 is made from a pure alloy, using an economical manufacturing process which makes it very competitive for universal machining
- + Multipurpose wire, price oriented
- + Suitable for all commercially available machines
- + AC Brass LP 900 is recommended for standard applications

### SPECIFICATIONS

Coating: Not coated

Conductivity: 22% IACS

Elongation: 1.5%

Material: Brass CuZn37

Resistance: 900 N/mm<sup>2</sup>

### TECHNICAL DETAILS

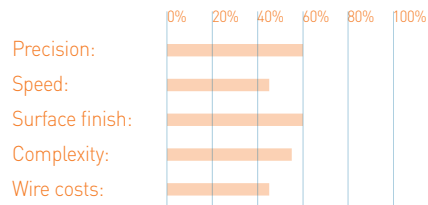

	Reference	Wire diameter (mm)	Resistance (N/mm <sup>2</sup> )	Spool / Package	Spool weight (kg)	Spool type
<b>TV</b>	950-304-407	0.20	900	2	8	K160
<b>KQ</b>	950-304-607	0.20	900	2	8	K160
<b>TV</b>	950-304-408	0.20	900	1	16	K200
<b>KQ</b>	950-304-608	0.20	900	1	16	K200
<b>TV</b>	950-304-412	0.20	900	2	10	P10
<b>TV</b>	950-304-415	0.25	900	4	4	K125
<b>B</b>	950-304-216	0.25	900	2	8	K160
<b>TV</b>	950-304-416	0.25	900	2	8	K160
<b>KQ</b>	950-304-616	0.25	900	2	8	K160
<b>B</b>	950-304-217	0.25	900	1	16	K200
<b>TV</b>	950-304-417	0.25	900	1	16	K200
<b>KQ</b>	950-304-617	0.25	900	1	16	K200
<b>B</b>	950-304-218	0.25	900	1	25	K250
<b>TV</b>	950-304-418	0.25	900	1	25	K250
<b>KQ</b>	950-304-618	0.25	900	1	25	K250
<b>TV</b>	950-304-420	0.25	900	4	5	P5



### Producer

**B** Berkenhoff

**TV** Thermocompact (VN)

**KQ** KQ

# AC Brass LP 900

## Brass wire

	Reference	Wire diameter (mm)	Resistance (N/mm <sup>2</sup> )	Spool / Package	Spool weight (kg)	Spool type
<b>KQ</b>	950-304-620	0.25	900	4	5	P5
<b>TV</b>	950-304-421	0.25	900	2	10	P10
<b>KQ</b>	950-304-621	0.25	900	2	10	P10
<b>B</b>	950-304-222	0.25	900	1	20	P15
<b>TV</b>	950-304-422	0.25	900	1	20	P15
<b>KQ</b>	950-304-622	0.25	900	1	20	P15
<b>TV</b>	950-304-424	0.30	900	4	4	K125
<b>TV</b>	950-304-425	0.30	900	2	8	K160
<b>KQ</b>	950-304-625	0.30	900	2	8	K160
<b>B</b>	950-304-226	0.30	900	1	16	K200
<b>TV</b>	950-304-426	0.30	900	1	16	K200
<b>KQ</b>	950-304-626	0.30	900	1	16	K200
<b>B</b>	950-304-227	0.30	900	1	25	K250
<b>TV</b>	950-304-427	0.30	900	1	25	K250
<b>TV</b>	950-304-428	0.30	900	1	45	K355
<b>TV</b>	950-304-429	0.30	900	4	5	P5
<b>TV</b>	950-304-430	0.30	900	2	10	P10
<b>KQ</b>	950-304-630	0.30	900	2	10	P10



## Producer

**B** Berkenhoff

**TV** Thermocompact (VN)

**KQ** KQ



# AC Brass LP 500

## Brass wire



### CHARACTERISTIC

- + AC Brass LP 500 is made from a pure alloy, using an economical manufacturing process which makes it very competitive for conic machining
- + Suitable for all commercially available machines
- + AC Brass LP 500 is particularly recommended for standard applications with large tapers  $> 8^\circ$

### SPECIFICATIONS

Coating: Not coated

Conductivity: 25% IACS

Elongation: 20%

Material: Brass CuZn37

Resistance: 500 N/mm<sup>2</sup>

### TECHNICAL DETAILS

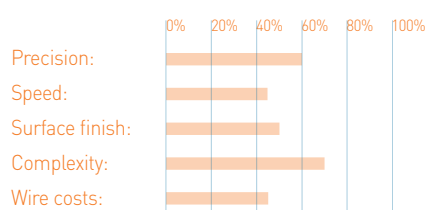

	Reference	Wire diameter (mm)	Resistance (N/mm <sup>2</sup> )	Spool / Package	Spool weight (kg)	Spool type
<b>TV</b>	950-303-415	0.25	500	4	4	K125
<b>KQ</b>	950-303-615	0.25	500	4	4	K125
<b>TV</b>	950-303-416	0.25	500	2	8	K160
<b>KQ</b>	950-303-616	0.25	500	2	8	K160
<b>B</b>	950-303-216	0.25	500	2	8	K160
<b>B</b>	950-303-217	0.25	500	1	16	K200
<b>TV</b>	950-303-417	0.25	500	1	16	K200
<b>KQ</b>	950-303-617	0.25	500	1	16	K200
<b>B</b>	950-303-218	0.25	500	1	25	K250
<b>TV</b>	950-303-418	0.25	500	1	25	K250
<b>B</b>	950-303-220	0.25	500	4	5	P5
<b>TV</b>	950-303-420	0.25	500	4	5	P5
<b>B</b>	950-303-222	0.25	500	1	20	P15
<b>TV</b>	950-303-424	0.30	500	4	4	K125
<b>TV</b>	950-303-425	0.30	500	2	8	K160
<b>B</b>	950-303-226	0.30	500	1	16	K200
<b>TV</b>	950-303-426	0.30	500	1	16	K200
<b>TV</b>	950-303-429	0.30	500	4	5	P5

### Producer

**B** Berkenhoff

**KQ** KQ

**TV** Thermocompact (VN)

# AC Cut XL

Copper wire coated with zinc coating homogenized



## CHARACTERISTIC

- + AC Cut XL is a high-speed wire using an economical manufacturing process which makes it very competitive
- + AC Cut XL is up to 15% faster than standard brass wire
- + 100% compatible with AC Cut X technologies
- + AC Cut XL reduces production costs in standard applications

## SPECIFICATIONS

Coating: Zinc diffused

Conductivity: 80% IACS

Elongation: 1%

Material: Copper (Cu)

Resistance: 450 N/mm<sup>2</sup>

## TECHNICAL DETAILS

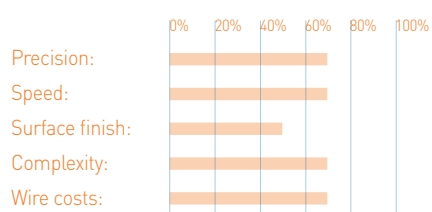

	Reference	Wire diameter (mm)	Resistance (N/mm <sup>2</sup> )	Spool / Package	Spool weight (kg)	Spool type
<b>B</b>	950-003-201	0.25	450	2	8	K160
<b>TV</b>	950-003-401	0.25	450	2	8	K160
<b>B</b>	950-003-202	0.25	450	1	16	K200
<b>TV</b>	950-003-402	0.25	450	1	16	K200

## Producer

**B** Berkenhoff

**TV** Thermocompact (VN)



# Fine wires



**Original**

high-end consumables line

# AC Cut Micro A

## High-tensile zinc-coated brass wire



### CHARACTERISTIC

- + AC Cut Micro A for high-quality machining and surface finish dedicated to micro machining
- + Available in diameters from 0.05 to 0.1 mm
- + AC Cut Micro A is recommended for high-quality applications that include very small details

### SPECIFICATIONS

Coating: Zinc treated

Conductivity: -

Elongation: 1%

Material: Brass CuZn37

Resistance: 1000 N/mm<sup>2</sup>

### TECHNICAL DETAILS

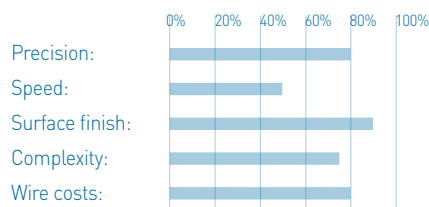

	Reference	Wire diameter (mm)	Resistance (N/mm <sup>2</sup> )	Spool / Package	Meters	Spool type
<b>B</b>	950-401-200	0.05	1000	1	10000	K100
<b>B</b>	950-401-204	0.07	1000	1	20000	K100
<b>B</b>	950-401-205	0.07	1000	1	30000	K100
<b>B</b>	950-401-217	0.10	1000	1	20000	K125
<b>B</b>	950-401-218	0.10	1000	1	30000	K125
<b>B</b>	950-401-219	0.10	1000	1	60000	K125

### Producer

**B** Berkenhoff

# AC Cut Micro SP-Z

High-tensile steel-core wire



## CHARACTERISTIC

- + AC Cut Micro SP-Z for finest machining with perfect precision and surface finish
- + Available in diameters from 0.03 to 0.07 mm
- + Suitable for all commercially available machines
- + AC Cut Micro SP-Z is recommended for top quality, demanding applications that include very small and precise details

## SPECIFICATIONS

Coating: Special zinc alloy

Conductivity: -

Elongation: 3%

Material: Steel core

Resistance: 2300 N/mm<sup>2</sup>

## TECHNICAL DETAILS

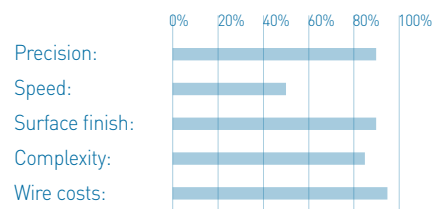

	Reference	Wire diameter (mm)	Resistance (N/mm <sup>2</sup> )	Spool / Package	Meters	Spool type
<b>Te</b>	950-403-001	0.05	2300	1	5000	50Z
<b>Te</b>	950-403-002	0.05	2300	1	10000	50Z
<b>Te</b>	950-403-010	0.05	2300	1	20000	50Z
<b>Te</b>	950-403-003	0.07	2300	1	5000	70Z
<b>Te</b>	950-403-004	0.07	2300	1	10000	70Z
<b>Te</b>	950-403-005	0.07	2300	1	20000	70Z
<b>Te</b>	950-403-015	0.07	2300	1	20000	70S

## Producer



# AC Cut Micro S

High-tensile steel-core wire



## CHARACTERISTIC

- + AC Cut Micro S for finest machining with perfect precision and surface finish
- + Available in diameters from 0.03 to 0.10 mm
- + AC Cut Micro S is recommended for top quality, demanding applications that include very small and precise details

## SPECIFICATIONS

Coating: CuZn50, Ag

Conductivity: -

Elongation: 1%

Material: Steel core

Resistance: 2000 N/mm<sup>2</sup>

## TECHNICAL DETAILS

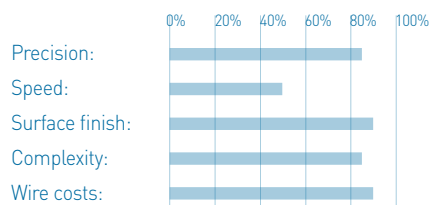

	Reference	Wire diameter (mm)	Resistance (N/mm <sup>2</sup> )	Spool / Package	Meters	Spool type
<b>B</b>	950-400-201	0.03	2000	1	5000	K100
<b>B</b>	950-400-203	0.05	2000	1	5000	K100
<b>B</b>	950-400-204	0.05	2000	1	10000	K100
<b>B</b>	950-400-206	0.06	2000	1	10000	K100
<b>B</b>	950-400-207	0.07	2000	1	5000	K100
<b>B</b>	950-400-208	0.07	2000	1	10000	K100
<b>B</b>	950-400-210	0.07	2000	1	30000	K125
<b>B</b>	950-400-212	0.08	2000	1	10000	K100
<b>B</b>	950-400-219	0.10	2000	1	5000	K100
<b>B</b>	950-400-220	0.10	2000	1	10000	K100
<b>B</b>	950-400-221	0.10	2000	1	20000	K125
<b>B</b>	950-400-222	0.10	2000	1	30000	K125

## Producer

**B** Berkenhoff

# AC Cut Micro TW

High-tensile strength tungsten wire



## CHARACTERISTIC

- + AC Cut Micro TW for high-quality machining
- + Suitable for all universal micro wire WEDM machining
- + AC Cut Micro TW is recommended for high-quality applications that include very small details

## SPECIFICATIONS

Coating: Not coated

Conductivity: 18,2 S/cm

Elongation: 2%

Material: Tungsten

Resistance: 2300 N/mm<sup>2</sup>

## TECHNICAL DETAILS

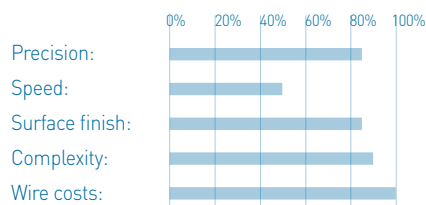

	Reference	Wire diameter (mm)	Resistance (N/mm <sup>2</sup> )	Spool / Package	Meters	Spool type
<b>S</b>	950-404-005	0,02	2300	1	5000	P1
<b>S</b>	838-102-500	0,025	2300	1	5000	P1
<b>S</b>	950-404-006	0,03	2300	1	5000	P1
<b>S</b>	838-104-000	0,04	2300	1	5000	P1
<b>S</b>	950-404-007	0,05	2300	1	5000	P1
<b>S</b>	838-106-000	0,06	2300	1	5000	P1
<b>S</b>	838-107-000	0,07	2300	1	5000	P1
<b>S</b>	838-108-000	0,08	2300	1	5000	P1
<b>S</b>	838-109-000	0,09	2300	1	5000	P1
<b>S</b>	838-110-000	0,10	2300	1	5000	P1
<b>S</b>	838-112-500	0,125	2300	1	5000	P1

## Producer

**S** Sumitomo



# AC Cut Micro TWS

High tensile strength tungsten wire



## CHARACTERISTIC

- + AC Cut Micro TWS for high-quality machining and surface finish
- + Available in diameters from 0.02 to 0.10 mm
- + This wire is intended for AgieCharmilles machines equipped with an IPG generator
- + AC Cut Micro TWS is recommended for high-quality applications that include very small details

## SPECIFICATIONS

Coating: Not coated

Conductivity: -

Elongation: < 5%

Material: Tungsten

Resistance: 3400 N/mm<sup>2</sup>

## TECHNICAL DETAILS

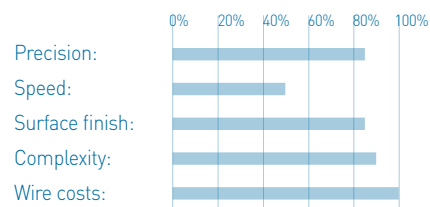

	Reference	Wire diameter (mm)	Resistance (N/mm <sup>2</sup> )	Spool / Package	Meters
<b>S</b>	950-404-000	0.02	3400	1	3000
<b>S</b>	950-404-001	0.03	3400	1	3000
<b>S</b>	950-404-002	0.05	3400	1	5000
<b>S</b>	950-404-003	0.07	3400	1	5000
<b>S</b>	950-404-004	0.10	3400	1	5000

## Producer

**S** Sumitomo

# AC Cut Micro Brass

Brass wire



## CHARACTERISTIC

- + AC Cut Micro Brass is made from a very pure alloy in order to guarantee consistent quality and performance in universal micro machining
- + Available in diameters from 0.10 to 0.07 mm
- + AC Cut Micro Brass is recommended for standard applications that include very small details

## SPECIFICATIONS

Coating: Not coated

Conductivity: -

Elongation: 1%

Material: Brass CuZn37

Resistance: 1000 N/mm<sup>2</sup>

## TECHNICAL DETAILS

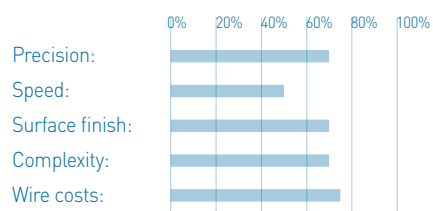

	Reference	Wire diameter (mm)	Resistance (N/mm <sup>2</sup> )	Spool / Package	Meters	Spool type
<b>B</b>	950-402-204	0.07	1000	1	20000	K125
<b>B</b>	950-402-205	0.07	1000	1	30000	K125
<b>B</b>	950-402-217	0.10	1000	1	20000	K125
<b>B</b>	950-402-219	0.10	1000	1	60000	K125

## Producer

**B** Berkenhoff

# AC Cut A 900

## Precision zinc-coated brass wire

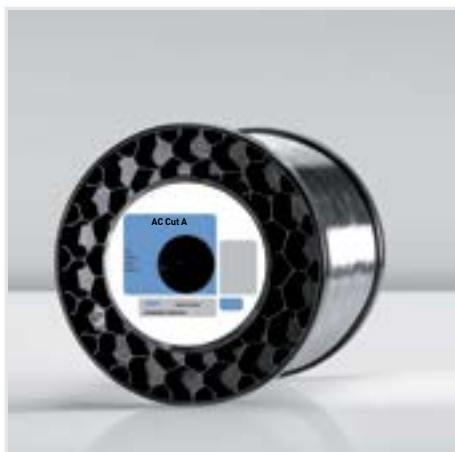

### CHARACTERISTIC

- + AC Cut A 900 is the benchmark wire for very high-quality machining
- + Perfect surface homogeneity and fine surface roughness <math>< Ra 0.1 \mu m</math>
- + Highest precision on geometrical details and part parallelism
- + Recommended for a wide range of applications including molds, cutting tools and general mechanical parts that require very high precision and excellent surface finish

### SPECIFICATIONS

Coating: Zinc  
 Conductivity: 22% IACS  
 Elongation: 1%  
 Material: Brass CuZn37  
 Resistance: 900 N/mm<sup>2</sup>

### TECHNICAL DETAILS

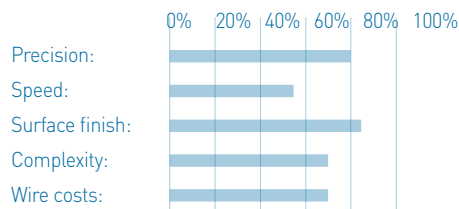

	Reference	Wire diameter (mm)	Resistance (N/mm <sup>2</sup> )	Spool / Package	Spool weight (kg)	Spool type
<b>T</b>	950-101-100	0.07	900	1	1.8	K100
<b>T</b>	950-101-101	0.10	900	1	1.8	K100
<b>T</b>	950-101-102	0.10	900	1	4	T125
<b>B</b>	950-101-202	0.10	900	4	4	K125
<b>T</b>	950-101-140	0.10	900	1	2	T125
<b>T</b>	950-101-103	0.10	900	4	5	P5

### Producer

**T** Thermocompact

**B** Berkenhoff

# AC Cut AH 900

Coated high-performance brass wire



## CHARACTERISTIC

- + AC Cut AH is the new generation of A wire. It combines perfect surface quality and extremely highly productivity
- + Perfect surface homogeneity and fine surface roughness <math>< Ra 0.1 \text{ (Oil bath) to } Ra 0.5 \mu\text{m}</math> )
- + Highest precision on geometrical details and part parallelism
- + Combined with the performance of the latest generators, it makes it possible to obtain part cost reductions of up to 20%
- + The perfect solution for complex parts, also ideal for punches and dies in steel or carbide

## SPECIFICATIONS

Coating: Special zinc alloy gamma diffused

Conductivity: 21% IACS

Elongation: 1.5%

Material: Brass CuZn37

Resistance: 900 N/mm<sup>2</sup>

## TECHNICAL DETAILS

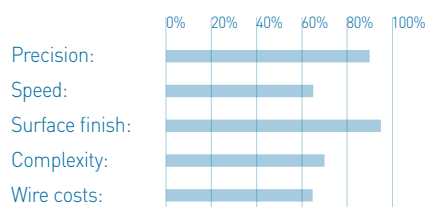

	Reference	Wire diameter (mm)	Resistance (N/mm <sup>2</sup> )	Spool / Package	Spool weight (kg)	Spool type
<b>T</b>	950-100-101	0.10	900	1	1.8	K100
<b>T</b>	950-100-102	0.10	900	1	4	T125
<b>T</b>	950-100-140	0.10	900	1	2	T125

## Producer

**T** Thermocompact

# AC Brass 900

High-quality brass wire

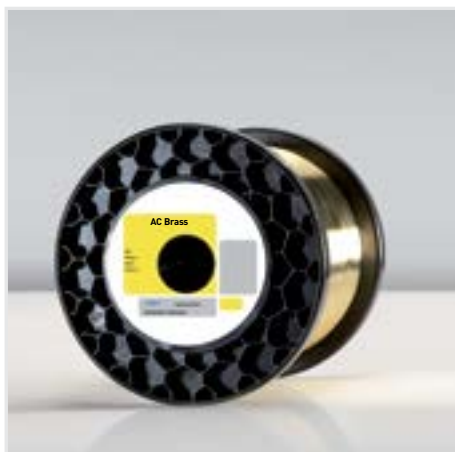

## CHARACTERISTIC

- + AC Brass 950 PF is a high-quality wire made from a very pure alloy in order to guarantee consistent quality and performance for high-end machining
- + Multipurpose wire
- + Suitable for all commercially available machines
- + AC Brass 900 is recommended for standard applications

## SPECIFICATIONS

Coating: Not coated

Conductivity: 22% IACS

Elongation: 1.5%

Material: Brass CuZn37

Resistance: 900 N/mm<sup>2</sup>

## TECHNICAL DETAILS

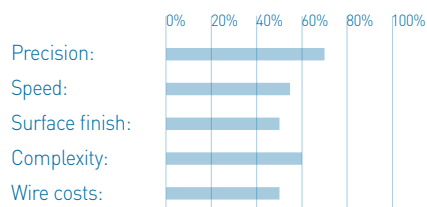

	Reference	Wire diameter (mm)	Resistance (N/mm <sup>2</sup> )	Spool / Package	Spool weight (kg)	Spool type
<b>T</b>	950-302-101	0.10	900	1	4	K125
<b>B</b>	950-302-201	0.10	900	4	4	K125

## Producer

**T** Thermocompact

**B** Berkenhoff

# AC Brass 950 PF\*

High-quality brass wire

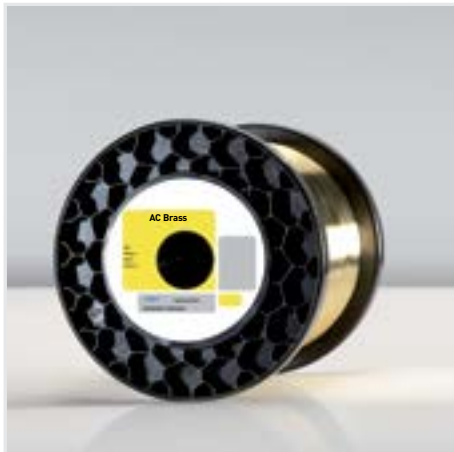

## CHARACTERISTIC

- + AC Brass 950 PF is a high-quality wire made from a very pure alloy in order to guarantee consistent quality and performance for high-end machines
- + Special processes are used to manufacture this wire in order to increase its straightness
- + Suitable for all commercially available machines
- + Particularly recommended for Fanuc and Mitsubishi machines
- + AC Brass 950 PF is recommended for standard applications that require high precision and good surface quality
- + Paraffin-free

## SPECIFICATIONS

Coating: Not coated

Conductivity: 22% IACS

Elongation: 1.5%

Material: Brass CuZn37

Resistance: 950 N/mm<sup>2</sup>

## TECHNICAL DETAILS

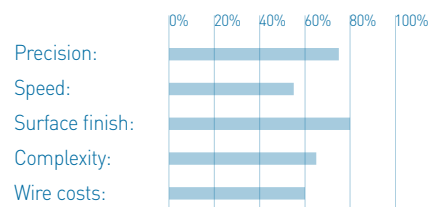

Reference	Wire diameter (mm)	Resistance (N/mm <sup>2</sup> )	Spool / Package	Spool weight (kg)	Spool type
950-305-503	0.10	950	2	3	K125

## Producer



Oki

\*Approval process underway



# Additional information and reference tables





# Wire types comparison table

## Standard wires

Agie Charmilles	Thermocompact	Bedra	Intech	Technos	OKI
AC Cut A 900	SWA	COBRA CUT® A	Alphacut 800		
AC Cut D 900	SWD	COBRA CUT® D			
AC Cut A 500	SWS	COBRA CUT	Alphacut 500		
AC Cut D 500	SWW	COBRA CUT® W			
AC Cut X	SWX	BRONCOCUT® X			
AC Cut XL	Thermo XL (Vietnam)	AC CUT XL			
AC Cut Xcc	SWXcc				
AC Cut XS	Thermo TEX	TOPAS® plus X			
AC Cut AL	Thermo A (Vietnam)	COBRACUT® pro / AS			
AC Cut VL	Thermo SD 500/900				
AC Cut AH 900	Thermo SA 900				
AC Cut AH 500	Thermo SA 500				
AC Cut AH 400	Thermo SA 400				
AC Cut GV		TOPAS® plus G			
AC Cut VS 500	Thermo SD 500	TOPAS® plus S			
AC Cut VS 900	Thermo SD 900	TOPAS® plus H			
AC Cut VH	Thermo SE	TOPAS® plus D			
AC Brass 400	Wire Brass 400	BERCOCUT® 400			
AC Brass 500	Wire Brass 500	BERCOCUT® 500	Superbrass 500		
AC Brass 900	Wire Brass 900	BERCOCUT® spezial	Superbrass 900		
AC Brass LP 400	Wire Brass 400 (Vietnam)				
AC Brass LP 500	Wire Brass 500 (Vietnam)				
AC Brass LP 900	Wire Brass 900 (Vietnam)	BERCOCUT® pro 900	Premium Brass 900		
AC Cut G		COBRA CUT® G			
AC Cut S		COBRA CUT® S			
AC Brass 950 PF			Superbrass Plus		OKI NP

## Fine wires

AgieCharmilles	Thermocompact	Bedra	Intech	Technos	Sumitomo
Ac Micro A		Microcut ® CCA			
AC Cut Micro SP-Z				SP-Z	
AC Cut Micro S		Microcut ®			
AC Cut Micro TWS					TWS-50
AC Cut Micro Brass		Microcut BR			
AC Brass 950 PF			Superbrass Plus		OKI NP

# Spools technical properties

## Bedra

Type of spool	Wire diameter (mm)	Nominal weight per spool (approx. kg)	Nominal length per spool* (m)	Run-off times per spool at run-off time speeds			
				6 m/min (h)	9 m/min (h)	12 m/min (h)	15 m/min (h)
bedra4	0,15	4	26800	74	50	37	30
	0.20	4	15000	42	28	21	17
	0.25	4	9600	27	18	13	11
	0.30	4	6600	18	12	9	7
bedra8 et K160 - 8 kg	0,15	8	53600	149	99	74	60
	0,20	8	30000	83	56	42	33
	0,25	8	19200	53	36	27	21
	0,30	8	13200	37	24	18	15
	0,33	8	10700	30	20	15	12
bedra16	0,20	16	60000	167	111	83	67
	0,25	16	38400	107	71	53	43
	0,30	16	26400	73	49	37	29
	0,33	16	21400	59	40	30	24
K100	0,15	1,6	10500	29	19	15	12
	0,20	1,6	6000	17	11	8	7
	0,25	1,6	3700	10	7	5	4
	0,30	1,6	2600	7	5	4	3
K125	0,15	3,5	23000	64	43	32	26
	0,20	3,5	12500	35	23	17	14
	0,25	3,5	8000	22	15	10	9
	0,30	3,5	5500	5	10	8	6
K160 - 6 kg	0,15	6	39000	108	72	54	43
	0,20	6	22000	61	41	31	24
	0,25	6	14000	39	26	19	16
	0,30	6	9800	27	18	14	11
K200	0,20	15,7	57500	160	106	80	64
	0,25	15,7	37000	103	69	51	41
	0,30	15,7	25800	72	48	36	29
	0,33	15,7	21200	59	39	29	24
K250	0,20	25	93750	260	174	130	104
	0,25	25	60000	167	111	83	67
	0,30	25	41250	115	76	57	46
	0,33	25	33500	93	62	47	37
K355	0,20	45	165000	458	306	229	183
	0,25	45	106000	294	196	147	118
	0,30	45	73500	204	136	102	82
	0,33	45	60700	167	112	84	67
P3	0,15	3	19700	55	36	27	22
	0,20	3	11000	31	20	15	12
	0,25	3	7000	19	13	10	8
	0,30	3	4900	14	9	7	5
P5	0,15	5	32600	91	60	45	36
	0,20	5	18300	51	34	25	20
	0,25	5	11700	33	22	16	13
	0,30	5	8100	23	15	11	9
	0,33	5	6740	19	12	9	7

\*Valid for full spools with CuZn alloys with a density of 8.67 kg/dm<sup>3</sup>



Type of spool	Wire diameter (mm)	Nominal weight per spool (approx. kg)	Nominal length per spool* (m)	Run-off times per spool at run-off time speeds			
				6 m/min (h)	9 m/min (h)	12 m/min (h)	15 m/min (h)
P10	0,20	10	36600	102	68	51	41
	0,25	10	23400	65	43	33	26
	0,30	10	16200	45	30	23	18
	0,33	10	13500	36	25	19	15
P15	0,20	20	73500	204	136	102	82
	0,25	20	46800	130	87	65	52
	0,30	20	32400	90	60	45	36
	0,33	20	27000	75	50	37	30
BK100	0,02 - 0,10		5000	14	9	7	5
bedra4	0,02 - 0,10		10000	28	18	14	11
	0,02 - 0,10		20000	56	36	28	22

\*Valid for full spools with CuZn alloys with a density of 8.67 kg/dm<sup>3</sup>



## Thermocompact

### Thermo SWA

Type of spool	Wire diameter (mm)	Nominal weight per spool (approx. kg)	Nominal length per spool* (m)
K100	0,07	1,8	58500
	0,10	1,8	27000
	0,127	1,8	16800
	0,15	1,8	12000
T125	0,10	4	60000
	0,127	4	37300
	0,15	4	26700
	0,20	4	14900
	0,25	4	9600
	0,30	4	6600
T160	0,127	8	74600
	0,15	8	53400
	0,20	8	29900
	0,25	8	19200
	0,30	8	13200
T200	0,20	16	59800
	0,25	16	38400
	0,30	16	26500
K250	0,25	25	60000
	0,30	25	41400
JP5	0,10	5	60000
	0,127	5	37300
	0,15	5	26700
	0,20	5	14900
	0,25	5	9600
	0,30	5	6600
JP10	0,15	10	67000
	0,20	10	37500
	0,25	10	24000
	0,30	10	16600



Type of spool	Wire diameter (mm)	Nominal weight per spool (approx. kg)	Nominal length per spool* (m)
JP15	0,20	20	74800
	0,25	20	48000
	0,30	20	33100



### Thermo Xcc

Type of spool	Wire diameter (mm)	Nominal weight per spool (approx. kg)	Nominal length per spool* (m)
T160	0,25	8	19200
	0,30	8	13200
	0,33	8	10700
T200	0,25	16	38400
	0,30	16	26500
	0,33	16	21400
K250	0,25	25	60000
	0,30	25	41400
	0,33	25	33400
JP15	0,25	20	48000
	0,30	20	33100
	0,33	20	26500

# Packaging units

## Bedra

	Weight / Spool [kg]	Spools / Carton	Weight / Carton [Kg]	Cartons / Layer	Weight 1 Layer [kg]	Weight 2 Layer [kg]	Weight 3 Layer [kg]	Weight 4 Layer [kg]
bedra4	4	4	16	6	96	192	288	384
bedra8	8	2	16	10	160	320	480	640
bedra16	16	1	16	12	192	384	576	
K125	3,5	4	14	6	84	168	252	336
K160	8	2	16	10	160	320	480	640
K200	16	1	16	12	192	384	576	
K250	25	1	25	12	300	600		
K355	45	1	45	3	135			
P5	5	4	20	8	160	320	480	640
P10	10	2	20	8	160	320	480	640
P15	20	1	20	16	320	640		

Weight = EuroWeight (1200 x 800)

Minimum order quantity for retailers: 1 layer

## Thermocompact

	Weight / Spool [kg]	Weight / Carton [kg]	Spools / Carton	Packages / Weight	Net Weight pallet [kg]
T125	4	16	4	24	384
T160	8	16	2	30	480
T200	16	16	1	24	384
K125	4	16	4	24	384
K160	8	16	2	30	480
K200	16	16	1	24	384
K250	20	25	1	18	450
K355	45	45	1	6	270
JP5	5	20	4	24	480
JP10	10	20	2	18	360
JP15	20	20	1	24	480

Weight = EuroWeight (1200 x 800)

# Correct wire storage

Please note:

## 1. Always store spools in their original packaging in a dry place.

The spools are packed in shock, dust and oxidation-proof material to protect the wire from shipping damage and contamination. The wire should be stored in the original packaging until ready for use. This will ensure the highest quality for your EDM applications.

## 2. Used spools handling procedures.

It is very important to properly secure the loose end of the wire on partially used spools. This will prevent the wire from shifting on the spool and becoming tangled. Improper handling and storage techniques can cause unwinding problems and unnecessary wire breakage.

Figures 1 and 2 show two correct ways to secure the loose end of the wire.

Figures 3 and 4 show incorrect ways and should definitely be avoided. Partially used spool should be stored in their original packaging material when not in use. This will minimize contamination and shifting of the wire on the spool.

## Proper handling of partially used spools:

Figure 1

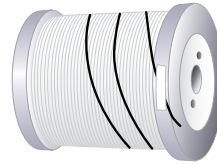

Attach wire to spool flange with tape.

Figure 2

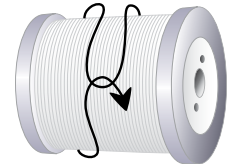

Attach wire by making a loop and securing it to itself. Make sure that the wire is snug.

## Strictly avoid:

Figure 3

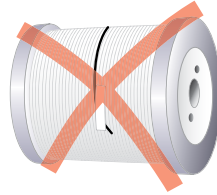

Do not tape wire to the spooled material!

Figure 4

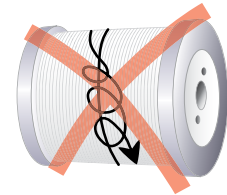

Do not thread the wire underneath itself so as to overlap!

**Warranty will be voided in case of improper storage!**

## Important!

To prevent the wire kinking, the core of the wire spool must be stored horizontally: the wire spool must rest laterally on both flanges, not on one of the basic flanges.

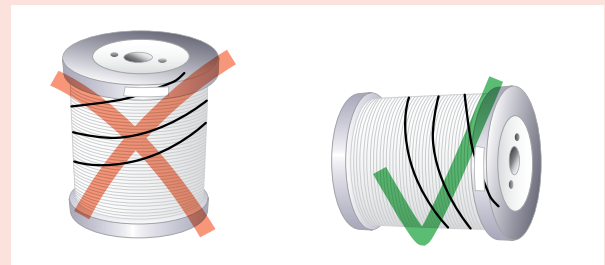

# Spool dimensions

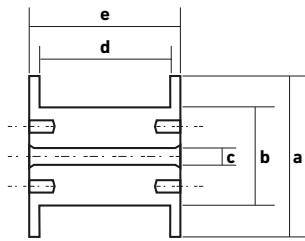

- a = Flange
- b = Core
- c = Bore
- d = Inside dimension
- e = Outside dimension

## Bedra + Thermocompact

Type	Flange a	Core b	Bore c	Inside dimension d	Outside dimension e
bedra4	130	80	16	105	125
bedra8	160	100	22	135	160
bedra16	200	125	22	164	200
TecSpool 125	125	80	16	100	125
TecSpool 160	160	100	22	128	160
TecSpool 200	200	125	22	160	200
K100	100	63	16	80	100
K125	125	80	16	100	125
K160	160	100	22	128	160
K200	200	125	22	160	200
K250	250	160	22	160	200
K355	355	224	36	160	200
P3	130	81	20	90	110
P5	160	90	20	90	115
P10	200	90	25	110	134
P15	250	110	34	110	140

# Filters for EDM machines

**Original**

high-end consumables line

**Compliant**

entry-level consumables line



# Content

Filters for water	
H15	067
H34	068
Micro filter	069
Security filter	069
Filters for water Compliant product series	
H15	071
Filter LP	071
H34	072
Filters for oil	
H15	075
Filter FACET	075

# Filters for water



**Original**

high-end consumables line

# H15

## Filter for water



### CHARACTERISTIC

- + Good filtration of dielectric fluids used in the EDM process is essential for the machining of high-quality parts
- + Our filters benefit from large filter surface and very high dirt holding capacity to offer excellent filtration performance and enable long service life
- + Available in various degrees of filter fineness and different type of medias, they are suitable for all EDM applications and their respective process requirements
- + Choose reliable, best quality filters to optimize your costs and productivity
- + Guarantee the optimal performance of your EDM machine

Reference	Designation	Outer diameter Inside diameter Height (mm)	Filter fineness ( $\mu\text{m}$ )	Filtration surface ( $\text{m}^2$ )	Flow direction	Medium type	Cap material	Quantity / Package
951-100-004	H15 190/16	150 / 32 x 375	3 - 5	3.1	Inside to outside	Single bellow	Plastic	4
951-100-001	H15 190/1	150 / 32 x 375	1 - 2	2.8	Inside to outside	Single bellow	Plastic	4



951-100-004



951-100-001

# H34

## Filter for water



### CHARACTERISTIC

- + Good filtration of dielectric fluids used in the EDM process is essential for the machining of high-quality parts
- + Our filters benefit from large filter surface and very high dirt holding capacity to offer excellent filtration performance and enable long service life
- + Available in various degrees of filter fineness and different type of medias, they are suitable for all EDM applications and their respective process requirements
- + Choose reliable, best quality filters to optimize your costs and productivity
- + Guarantee the optimal performance of your EDM machine

Reference	Designation	Outer diameter Inside diameter Height (mm)	Filter fineness (µm)	Filtration surface (m2)	Flow direction	Medium type	Cap material	Quantity / Package
951-100-012	H34 1158/20	340 / 47.5 x 450	3 - 5	14.5	Outside to inside	Single bellow	Metallic	1
951-100-017	H34 1390	340 / 404 x 300 (G 3/4")	3 - 5	13.5	Outside to inside	Double bellow	Plastic	1
951-100-022	H34 1790/2	340 / 47.5 x 450	3 - 5	17	Outside to inside	Single bellow/ Macro pleats	Plastic	1
951-100-023	H34 1790/3	340 / 47.5 x 450	3 - 5	14.5	Outside to inside	Single bellow	Plastic	1
951-100-024	H34 2090	340 / 404 x 450 (G 3/4")	3 - 5	20.6	Outside to inside	Double bellow	Plastic	1
951-100-041	H34 2240/20	340 x 450 (G 3/4")	3 - 5	22.4	Outside to inside	Double bellow	Metallic	1
951-100-066	H34 1490/14 Kit	340 / 404 x 300 (G 3/4")	1 - 2	14.8	Outside to inside	Triple bellow	Plastic	1
951-100-067	H34 1490/15 Kit	340 / 404 x 300 (G 3/4")	1 - 2	14.1	Outside to inside	Triple bellow	Plastic	1



951-100-012

951-100-017

951-100-022

951-100-023

951-100-024

951-100-041

951-100-066

951-100-067

# Micro filter

Filter for water



## CHARACTERISTIC

- + Good filtration of dielectric fluids used in the EDM process is essential for the machining of high-quality parts
- + Our filters benefit from large filter surface and very high dirt holding capacity to offer excellent filtration performance and enable long service life
- + Available in various degrees of filter fineness and different type of medias, they are suitable for all EDM applications and their respective process requirements
- + Choose reliable, best quality filters to optimize your costs and productivity
- + Guarantee the optimal performance of your EDM machine system

Reference	Designation	Outer diameter Inside diameter Height (mm)	Filter fineness ( $\mu\text{m}$ )	Filtration surface ( $\text{m}^2$ )	Flow direction	Medium type	Cap material	Quantity / Package
951-100-049	Filter 62x128mm 5 $\mu\text{m}$	62 / 27 x 128	5	-	Inside to outside	-	Plastic	1
135-015-401	Filter CUNO 5 $\mu\text{m}$							
200-001-908	Filter CUNO 3 $\mu\text{m}$							

# Security filter



## CHARACTERISTIC

- + For all old AGIE machines
- + For AC Vertex, AC Challenge, AC Progress, AC Classic of AgieCharmilles
- + For CUT 1000 / CUT 1000 OilTech

Reference	Designation
962-673-547	Micro filter (Security filter)

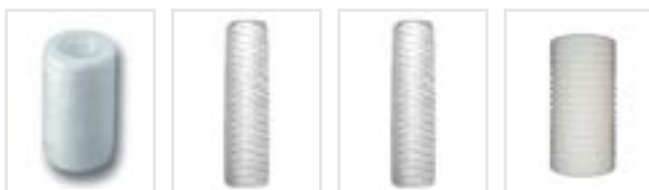

951-100-049

135-015-401

200-001-908

962-673-547



# **Filters for water** **Compliant product series**

**Compliant**

entry-level consumables line



# H15

Filter for water



## CHARACTERISTIC

- + Good filtration of dielectric fluids used in the EDM process is essential for the machining of high-quality parts
- + Our filters benefit from large filter surface and very high dirt holding capacity to offer excellent filtration performance and enable long service life
- + Available in various degrees of filter fineness and different type of medias, they are suitable for all EDM applications and their respective process requirements
- + Choose reliable, best quality filters to optimize your costs and productivity
- + Guarantee the optimal performance of your EDM machine

Reference	Designation	Outer diameter Inside diameter Height (mm)	Filter fineness ( $\mu\text{m}$ )	Filtration surface ( $\text{m}^2$ )	Flow direction	Medium type	Cap material	Quantity / Package
951-100-034	E-line/1	150 / 32 x 375	3 - 5	3.1	Inside to outside	Single bellow	Plastic	4

# Filter LP

Filter for water



## CHARACTERISTIC

- + Good filtration of dielectric fluids used in the EDM process is essential for the machining of high-quality parts
- + Our filters benefit from large filter surface and very high dirt holding capacity to offer excellent filtration performance and enable long service life
- + Available in various degrees of filter fineness and different type of medias, they are suitable for all EDM applications and their respective process requirements
- + Choose reliable, best quality filters to optimize your costs and productivity
- + Guarantee the optimal performance of your EDM machine

Reference	Designation	Outer diameter Inside diameter Height (mm)	Filter fineness ( $\mu\text{m}$ )	Filtration surface ( $\text{m}^2$ )	Flow direction	Medium type	Cap material	Quantity / Package
951-100-050	Filter LP 145x375mm 5 $\mu\text{m}$	145 / 31.5 x 375	5	2.97	Inside to outside	Single bellow	Plastic	6

# H34

## Filter for water



### CHARACTERISTIC

- + Good filtration of dielectric fluids used in the EDM process is essential for the machining of high-quality parts
- + Our filters benefit from large filter surface and very high dirt holding capacity to offer excellent filtration performance and enable long service life
- + Available in various degrees of filter fineness and different type of medias, they are suitable for all EDM applications and their respective process requirements
- + Choose reliable, best quality filters to optimize your costs and productivity
- + Guarantee the optimal performance of your EDM machine system

Reference	Designation	Outer diameter Inside diameter Height (mm)	Filter fineness (µm)	Filtration surface (m2)	Flow direction	Medium type	Cap material	Quantity / Package
951-100-015	H34 1290/3	340 / 45 x 300	3 – 5	10.5	Outside to inside	Single bellow/ Macro pleats	Plastic	1
951-100-016	H34 1380/1	340 x 300 (G 3/4")	1 – 2	14.2	Outside to inside	Double bellow	Metallic	1
951-100-018	H34 1390/2	340 / 404 x 300 (G 3/4")	10	12.8	Outside to inside	Double bellow	Plastic	1
951-100-020	H34 1780/2	340 x 450 (G 3/4")	3 – 5	17	Outside to inside	Single bellow	Metallic	1
951-100-033	H34 1380	340 x 300 (G 3/4")	3 – 5	14.2	Outside to inside	Double bellow	Metallic	1
951-100-036	H34 1070/1	340 / 47.5 x 300	1 – 2	9.2	Outside to inside	Single bellow	Metallic	1
951-100-037	H34 1070/20	340 / 45.5 x 300	3 – 5	10.7	Outside to inside	Single bellow	Metallic	1



951-100-015



951-100-016



951-100-018



951-100-020



951-100-033



951-100-036



951-100-037





# Filters for oil

A close-up photograph of several white, pleated oil filters. The filters are arranged in a fan-like pattern, with their pleated surfaces facing outwards. The lighting is soft, highlighting the texture of the filter media. The background is a dark, neutral color, making the white filters stand out.

**Original**

high-end consumables line

# H15

Filter for oil



## CHARACTERISTIC

- + Good filtration of dielectric fluids used in the EDM process is essential for the machining of high-quality parts
- + Our filters benefit from large filter surface and very high dirt holding capacity to offer excellent filtration performance and enable long service life
- + Available in various degrees of filter fineness and different type of medias, they are suitable for all EDM applications and their respective process requirements
- + Choose reliable, best quality filters to optimize your costs and productivity
- + Guarantee the optimal performance of your EDM machine system

Reference	Designation	Outer diameter Inside diameter Height (mm)	Filter fineness ( $\mu\text{m}$ )	Filtration surface ( $\text{m}^2$ )	Flow direction	Medium type	Cap material	Quantity / Package
951-101-001	Filter H15 475/1	150 / 32 x 375	3 – 5	4.5	Inside to outside	Single bellow	Plastic	4

# Filter FACET

Filter for oil



## CHARACTERISTIC

- + Plate filter
- + Only for die-sinking EDM

Reference	Designation	Outer diameter Inside diameter Height (mm)	Filter fineness ( $\mu\text{m}$ )	Filtration surface ( $\text{m}^2$ )	Flow direction	Medium type	Cap material	Quantity / Package
951-101-009	Filter LP 150x365mm 5 $\mu\text{m}$	150 / 31.5 x 365	5	3.8	Inside to outside	Single bellow	Metallic	6





# Deionization systems

**Original**

high-end consumables line





# Content

Resintech Ri20, Ri50, Ri20 HM	078
Mixed bed resin MB 9L	079
E.KO IONISER 1501	080
E.KO IONISER 1502	081
Connection kit with Korrostop for E.KO IONISER	082

# Resintech Ri20, Ri50, Ri20 HM



## CHARACTERISTIC

- + Resintech has quickly become the product of choice for resin in immersion tanks. This service saves erosion cutting machine users the trouble of emptying and topping up conventional tanks
- + The replacement service includes emptying, cleaning, topping up and proper disposal of waste resin
- + The patented ventilation principle destroys the resulting channeling in the resin bed thereby increases the service life

Reference	Description
951-000-000	Resintech Ri50 Monobloc - 45 l
951-000-006	Resintech Ri20 Monobloc - 18 l
951-000-003	Water connection kit
951-000-004	Resintech Air connection kit
951-000-009	Resintech Ri20 HM Monobloc - 18 l for carbide (Wc)
813-200-004	Prefilter Typ 250 Standard
885-003-300	Prefilter replacement
812-129-000	Trolley for tank 50 l
812-334-100	Greenline pre deionising. Ri50 Monoblock - 45 l
812-335-300	Greenline Refill. Ri50 Monoblock - 45 l
812-334-200	Greenline Connecting Set incl. cond. meter



951-000-000



951-000-006



951-000-003



951-000-004



813-200-004



812-129-000



812-334-100

# Mixed bed resin MB 9L



## CHARACTERISTIC

- + Amberlite MB 9L mixed-bed resin supplied by DOW (formerly Rohm & Haas) is especially suitable for erosion cutting
- + Its balanced ratio of anodes and cathodes results in an optimum product life. A conductance of 1  $\mu$ S can be achieved without any problem. The resin is adversely affected by the carbon dioxide in air. The resin mixture must be stored in airtight containers
- + Caution: Comply with the generally recommended precautions that must be taken for chemicals. Strong oxidizing agents, e.g. nitric acid, can cause violent reactions if they come into contact with ion exchange resins

Reference	Description
951-001-009	Resin bag 25 LT MB9
951-001-011	Resin drum 50 LT MB9
951-001-013	Resin bag 25 liters Amberjet 4500 OH
951-001-010	Resin bag 25 liters MB 20
951-001-017	Resin bag 25 liters MB 115

# E.KO IONISER 1501

For all standard applications



## CHARACTERISTIC

- + The equipment is only leased, it remains the property of EasyMetal GmbH (Austria)
- + Initial installation includes the connection kit with the Korrostop inspection device and connection by a GF Machining Solutions service technician
- + High flow rates and low conductance values guarantee a stable dielectric even in case of rough machining, this makes it possible to obtain very good results on workpieces
- + The Korroskop inspection device is used to monitor the conductance of the dielectric

Reference	Dimensions	Weight	Flow	Max. operating pressure	Conductivity
902-124-478	660 x 370 x 1150 mm	150 kg	40 Liter/min	5 bar	< 0.5 $\mu$ S



# E.KO IONISER 1502

Exclusively for hard metal machining



## CHARACTERISTIC

- + The equipment is only leased, it remains the property of EasyMetal GmbH (Austria)
- + Initial installation includes the connection kit with the Korrostop inspection device and connection by a GF Machining Solutions service technician
- + E.KO IONISER 1502 is designed exclusively for machining hard metal
- + If more than 30% hard metal is machined on an EDM machine, we expressly recommend the E.KO IONISER 1502 model
- + High flow rates and low conductance values guarantee a stable dielectric even in case of rough machining and this makes it possible to achieve very good results on workpieces
- + The Korrostop inspection device is used to monitor the conductance of the dielectric

Reference	Dimensions	Weight	Flow	Max. operating pressure	Conductivity
902-124-485	660 x 370 x 1150 mm	150 kg	40 Liter /min	5 bar	< 0.5 $\mu$ S

# Connection kit with Korrostop for E.KO IONISER



## CHARACTERISTIC

- + Every connection kit includes a Korrostop inspection device plus quick-release couplings, screw fittings etc. (excluding hose)
- + Other connection kits are available on request

Reference	Description
812-800-040	for AgieCharmilles and Charmilles machines (CT01)



812-800-040



# Dielectrics

The image features a dynamic, flowing stream of liquid, likely representing a dielectric material, cascading from the top left towards the bottom right. The liquid is rendered with vibrant, multi-colored highlights in shades of red, orange, yellow, and green, giving it a shimmering, ethereal appearance. The background is a dark, gradient grey, populated with a field of small, semi-transparent plus signs (+) in various colors including blue, green, yellow, orange, red, and purple. These plus signs are scattered across the lower half of the image, creating a sense of depth and texture. The overall composition is modern and scientific.

**Original**

high-end consumables line

# Content

Dielectric IonoFil	086
Dielectric IonoPlus	086
Dielectric IME 110	087
Dielectric IME 82	087
Dielectric IME 63	088
Additional Dielectric	088

# Dielectric IonoFil

For wire EDM



## CHARACTERISTIC

- + IonoFil is appropriate for fine-wire applications and very small radii
- + It is possible to achieve Ra values  $\leq 0.05 \mu\text{m}$  on latest-generation machines
- + The EDM system must be equipped with a fire extinguishing system
- + Completely synthetic high-performance dielectric with anti-cracking additives
- + IonoFil is a combination of ultrapure synthetic products that have been enriched with additives by using special blending techniques. IonoFil is physiologically harmless (non-toxic) when used as specified. There is no corrosion on workpieces or machinery compared with the previously used safe deionized water

Reference	Description	Color	Density at 15°C en g/cm <sup>3</sup> (DIN 51757)	Viscosity + 40°C en mm <sup>2</sup> /S (DIN 51562)	Flashpoint in °C (DIN EN ISO 2719)	Aromatics % (DIN 51378) max
962-000-055	IonoFil OH 2788 - Drum 208 Liter	IonoFil neon green	0.78	2.1	< 100	< 0.01
962-000-057	IonoFIL OH 2788 - Drum 60 Liter	IonoFil neon green	0.78	2.1	< 100	< 0.01

# Dielectric IonoPlus

For wire EDM

Reference	Description	Color	Density at 15°C en g/cm <sup>3</sup> (DIN 51757)	Viscosity + 40°C en mm <sup>2</sup> /S (DIN 51562)	Flashpoint in °C (DIN EN ISO 2719)	Aromatics % (DIN 51378) max
962-000-065	IonoPlus IME-MH - Drum 208 Liter	IonoPlus neon green	0.79	2.5	107	< 0.01
962-000-066	IonoPlus IME-MH - Drum 60 Liter	IonoPlus neon green	0.79	2.5	107	< 0.01

# Dielectric IME 110

For die-sinking machines



## CHARACTERISTIC

- + Dielectric IME 110 is mainly used in situations where, for safety reasons, a flashpoint in excess of 100 °C is required. It is suitable for universal use ranging from fine grinding through to rough machining. Particularly good results are obtained with graphite electrodes

Reference	Description	Color	Density at 15 °C en g/cm3 (DIN 51'757)	Viscosity + 40 °C en mm2/S (DIN 51'562)	Flashpoint in °C (DIN EN ISO 2719)	Aromatics % (DIN 51'378) max
962-000-039	IME 110 - Drum 208 Liter	water clear	0.775	3.4	106	0.01
962-000-040	IME 110 - Drum 60 Liter	water clear	0.775	3.4	106	0.01

# Dielectric

For die-sinking machines



## CHARACTERISTIC

- + Dielectric IME 82 combines high metal removal rates with low wear. It was developed for universal use in tool and mold making. This dielectric can even be used for rough machining using high current amperages

Reference	Description	Color	Density at 15 °C en g/cm3 (DIN 51'757)	Viscosity + 40 °C en mm2/S (DIN 51'562)	Flashpoint in °C (DIN EN ISO 2719)	Aromatics % (DIN 51'378) max
962-000-043	IME 82 - Drum 208 Liter	water clear	0.789	3.00	82	0.02
962-000-044	IME 82 - Drum 60 Liter	water clear	0.789	3.00	82	0.02

# Dielectric IME 63

For die-sinking machines



## CHARACTERISTIC

- + Dielectric IME 63 is extremely thin-bodied and has a very low surface tension. It is suitable for very fine work where the least possible overcut is required
- + This dielectric is 100% liable to VOC tax

Reference	Description	Color	Density at 15°C en g/cm3 (DIN 51757)	Viscosity + 40°C en mm2/S (DIN 51562)	Flashpoint in °C (DIN EN ISO 2719)	Aromatics % (DIN 51378) max
962-000-041	IME 63 - Drum 208 Liter	water clear	0.765	1.8	63	0.003
962-000-042	IME 63 - Drum 60 Liter	water clear	0.765	1.8	63	0.003

# Additional Dielectric

For die-sinking machines



Reference	Description	Color	Density at 15°C en g/cm3 (DIN 51757)	Viscosity + 40°C en mm2/S (DIN 51562)	Flashpoint in °C (DIN EN ISO 2719)	Aromatics % (DIN 51378) max
834-100-300	Concentrate Procesfluid Dr01 3 Liter	blank	-	-	-	-
834-101-000	Concentrate Procesfluid Dr01 10 Liter	blank	-	-	-	-
834-105-000	Vitol KS 20 Liter	blank	-	-	-	-



# Additional Dielectric

For die-sinking machines



## CHARACTERISTIC

- + 80S: For superfine machining
- + 95S: For fine machining and fine finishing
- + 108 Mp-s: Multipurpose high-performance dielectric
- + AD70: Drilling machine  $\leq 0,6$ mm diameter holes
- + M205: Multipurpose high-performance dielectric
- + HV: For High power rough grinding

Reference	Description	Color	Density at 15°C en g/cm <sup>3</sup> [DIN 51757]	Viscosity + 20°C en mm <sup>2</sup> /S [DIN 51562]	Flashpoint in °C [DIN EN ISO 2719]	Aromatics % [DIN 51378] max
962-000-045	Edm Fluid/80-S 205 Liter	blank	0,751	1,83	80	-
962-000-046	Edm Fluid/80-S 20 Liter	blank	0,751	1,83	80	-
962-000-047	Edm Fluid/95-S 205 Liter	blank	0,761	2,36	95	-
962-000-048	Edm Fluid/95-S 20 Liter	blank	0,761	2,36	95	-
962-000-049	Edm Fluid/108 Mp-S 205 Liter	blank	0,767	3	108	-
962-000-050	Edm Fluid/108 Mp-S 20 Liter	blank	0,767	3	108	-
834-260-200	Edm Fluid/AD70 205 Liter	blank	0,744	1,6	70	-
834-260-300	Edm Fluid/AD70 20 Liter	blank	0,744	1,6	70	-
834-280-200	Edm Fluid/Flusin M 205 Liter	blank	0,736	2,7	100	-
834-290-200	Edm Fluid/Flusin HV 205 Liter	blank	0,825	6	125	-

# Graphite electrodes

Original

high-end consumables line



# Content

Standard electrodes	
Square block milled surface	094
T-block	095
Square block polished surface	096
Cylinder	097
Conical plates	098
Thin plates	099
Saw Cut electrodes	101
Special electrodess	103

# Standard electrodes



**Original**

high-end consumables line

# GF EDM graphite properties

## GRAPHITE AC-K500 10µm

Specifications	Unit	Value
Density	g/cm <sup>3</sup>	1.78
Average grain size	µm	10
Bending strength	MPa	41
Electrical resistance	µm	11

## GRAPHITE AC-K600 8µm

Specifications	Unit	Value
Density	g/cm <sup>3</sup>	1.78
Average grain size	µm	8
Bending strength	MPa	52
Electrical resistance	µm	13.4

### Specific applications

- + Wear-resistant fine-grain graphite for exacting requirements

## GRAPHITE AC-K700 6µm

Specifications	Unit	Value
Density	g/cm <sup>3</sup>	1.80
Average grain size	µm	6
Bending strength	MPa	60
Electrical resistance	µm	13

### Specific applications

- + Grade for finishing to achieve especially good detail rendering for fine electrodes, superb milling results

## GRAPHITE AC-K800 4µm

Specifications	Unit	Value
Density	g/cm <sup>3</sup>	1.78
Average grain size	µm	4
Bending strength	MPa	73
Electrical resistance	µm	14

### Specific applications

- + Extremely fine grade for finishing to achieve superb surface qualities with comparatively high metal removal rates for extremely fine surfaces
- + Ultrafine electrodes, superb milling results

# Overview of the different graphites

## Graphites and achievable surface finish by graphite quality

GFAC Graphite	Grain size µm	Compressive strength Mg/m <sup>3</sup>	Shore hardness	Electrical resistance µΩ.m	Ra (µm)	5.00	3.15	2.00	1.25	0.80
					R max. (µm)	40-25	25-16	16-10	10-6.3	6.3-4
					VDI	36	35	34	33	32
AC-K800	4	1.78	72	14						
AC-K700	6	1.80	70	13						
AC-K600	8	1.78	63	13.4						
AC-K500	10	1.78	55	11						

# Square block

Milled surface

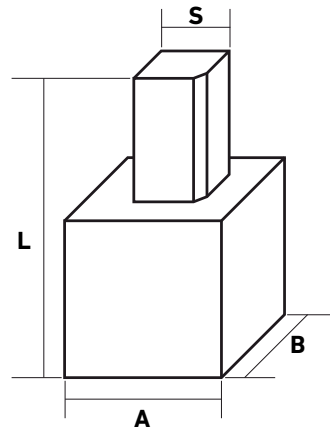

AC-K800	AC-K700	AC-K600	S (mm) Tol 0/+0.05	A X B (mm) Tol 0/+3	L (mm) Tol 0/+3	Surface finish	Quantity / Package
951-558-001	951-557-001	951-556-001	15 X 15	30 X 30	90	Milled & saw cut	15
951-558-002	951-557-002	951-556-002	15 X 15	40 X 40	90	Milled & saw cut	15
951-558-003	951-557-003	951-556-003	25 X 25	40 X 40	90	Milled & saw cut	8
951-558-004	951-557-004	951-556-004	25 X 25	50 X 50	90	Milled & saw cut	8
951-558-005	951-557-005	951-556-005	25 X 25	60 X 60	90	Milled & saw cut	8

# T-block

Milled surface

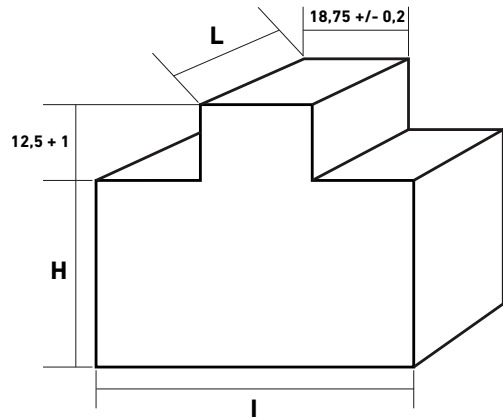

AC-K800	AC-K700	AC-K600	L (mm)	I (mm)	H (mm)	Tolerance (mm)	Surface finish	Quantity / Package
951-568-001	951-567-001	951-566-001	50	50	50	0/ +3	Milled & saw cut	12
951-568-002	951-567-002	951-566-002	100	50	50	0/ +3	Milled & saw cut	6
951-568-003	951-567-003	951-566-003	150	50	50	0/ +3	Milled & saw cut	4
951-568-004	951-567-004	951-566-004	300	50	50	0/ +3	Milled & saw cut	2
951-568-005	951-567-005	951-566-005	50	75	50	0/ +3	Milled & saw cut	6
951-568-006	951-567-006	951-566-006	100	75	50	0/ +3	Milled & saw cut	3
951-568-007	951-567-007	951-566-007	150	75	50	0/ +3	Milled & saw cut	2
951-568-008	951-567-008	951-566-008	300	75	50	0/ +3	Milled & saw cut	1
951-568-009	951-567-009	951-566-009	50	100	80	0/ +3	Milled & saw cut	6
951-568-010	951-567-010	951-566-010	100	100	80	0/ +3	Milled & saw cut	3
951-568-011	951-567-011	951-566-011	150	100	80	0/ +3	Milled & saw cut	2
951-568-012	951-567-012	951-566-012	300	100	80	0/ +3	Milled & saw cut	1

# Square block

Polished surface

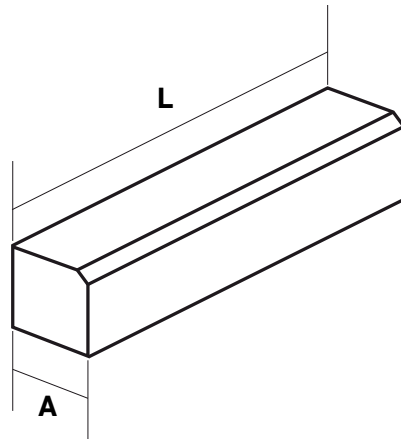

AC-K800	AC-K700	AC-K600	A (mm) Tot 0/+0.05	L (mm) Tot 0/+5	Surface finish	Quantity / Package
951-548-001	951-547-001	951-546-001	15 x 15	75	Polished	40
951-548-002	951-547-002	951-546-002	15 x 15	90	Polished	40
951-548-003	951-547-003	951-546-003	15 x 15	300	Polished	10
951-548-005	951-547-005	951-546-005	25 x 25	90	Polished	24
951-548-006	951-547-006	951-546-006	25 x 25	300	Polished	8



# Cylinder

Polished and turned surface

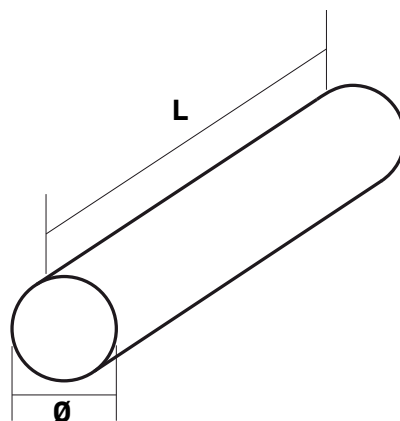

AC-K800	AC-K700	AC-K600	Ø (mm)	Length (mm) Tol. 0/+5	Tolerance Ø (mm)	Surface finish	Quantity / Package
951-528-005	951-527-005	951-526-005	5	300	0 / + 0.1	Turned	5
951-528-006	951-527-006	951-526-006	6	300	0 / + 0.1	Turned	5
951-528-008	951-527-008	951-526-008	8	300	0 / + 0.1	Turned	5
951-528-010	951-527-010	951-526-010	10	300	0 / + 0.1	Turned	5
951-528-015	951-527-015	951-526-015	15	300	0 / + 1	Turned	5
951-528-020	951-527-020	951-526-020	20	300	0 / + 1	Turned	5
951-528-025	951-527-025	951-526-025	25	300	0 / + 1	Turned	5
951-528-030	951-527-030	951-526-030	30	300	0 / + 1	Turned	5
951-528-040	951-527-040	951-526-040	40	300	0 / + 1	Turned	5
951-528-050	951-527-050	951-526-050	50	300	0 / + 1	Turned	5
951-528-060	951-527-060	951-526-060	60	300	0 / + 1	Turned	5
951-528-070	951-527-070	951-526-070	70	300	0 / + 1	Turned	5
951-528-080	951-527-080	951-526-080	80	300	0 / + 1	Turned	5

# Conical plates

Polished surface

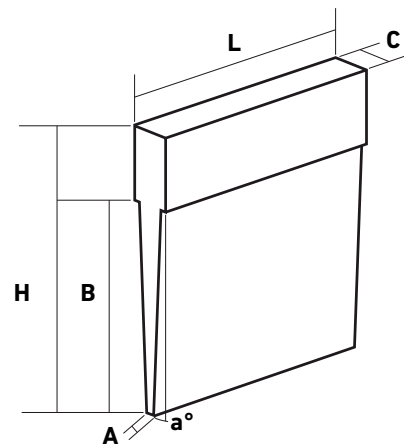

AC-K800	Angle [°]	Dimension: A x B x C Tot. 0/+0.03	H (mm) Tot. 0/+5	L (mm) Tot. 0/+5	Surface finish	Quantity / Package
951-538-001	0.5	1 x 80 x 3	100	150	Polished	1
951-538-002	0.5	2 x 80 x 4	100	150	Polished	1
951-538-003	1	1 x 80 x 4	100	150	Polished	1
951-538-004	1	2 x 80 x 5	100	150	Polished	1
951-538-005	1.5	1 x 76 x 5	100	150	Polished	1
951-538-006	1.5	2 x 76 x 6	100	150	Polished	1
951-538-007	2	1 x 76 x 7	100	150	Polished	1
951-538-008	2	2 x 71 x 7	100	150	Polished	1

# Thin plates

Polished surface

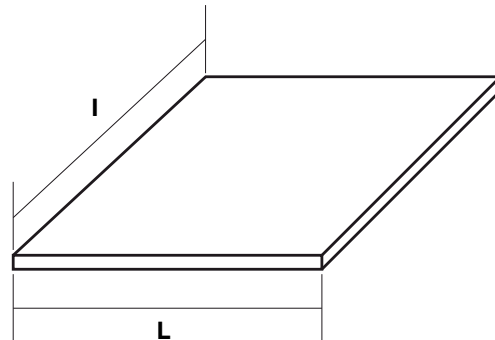

Reference	L (mm) Tol. 0/+5	l (mm) Tol. 0/+5	Thickness (mm) Tol. 0/+0.025	Surface finish	Quantity / Package
951-518-003	150	100	0.3	Polished	1
951-518-004	150	100	0.4	Polished	1
951-518-005	150	100	0.5	Polished	1
951-518-006	150	100	0.6	Polished	1
951-518-007	150	100	0.7	Polished	1
951-518-008	150	100	0.8	Polished	1
951-518-009	150	100	0.9	Polished	1
951-518-010	150	100	1	Polished	1
951-518-011	150	100	1.1	Polished	1
951-518-012	150	100	1.2	Polished	1
951-518-013	150	100	1.3	Polished	1
951-518-014	150	100	1.4	Polished	1
951-518-015	150	100	1.5	Polished	1
951-518-016	150	100	1.6	Polished	1
951-518-017	150	100	1.7	Polished	1
951-518-018	150	100	1.8	Polished	1
951-518-019	150	100	1.9	Polished	1
951-518-020	150	100	2	Polished	1
951-518-021	150	100	2.1	Polished	1
951-518-022	150	100	2.2	Polished	1
951-518-023	150	100	2.3	Polished	1
951-518-024	150	100	2.4	Polished	1
951-518-025	150	100	2.5	Polished	1

# Saw Cut electrodes



**Original**

high-end consumables line

# Saw Cut surfaces

## Belt grinding on request



	Reference	Tolerance (mm)	Surface finish	Max. size	Dimension A x B x C	CD3
AC-K800	951-508-000	0/+5mm	Saw Cut	610 x 390 x 190	X00 x X00 x X00	Order dm3
AC-K700	951-507-000	0/+5mm	Saw Cut	1230 x 480 x 260	X00 x X00 x X00	Order dm3
AC-K600	951-506-000	0/+5mm	Saw Cut	1230 x 500 x 400	X00 x X00 x X00	Order dm3
AC-K500	951-505-000	0/+5mm	Saw Cut	1230 x 500 x 400	X00 x X00 x X00	Order dm3

## Orders

For orders please contact your Customer Services Consultant who will coordinate the entire ordering process with the production plant. For each electrode you order please specify the volume (in dm3)

$$\frac{A \times B \times C}{1.000.000} = \text{Volume for the order}$$

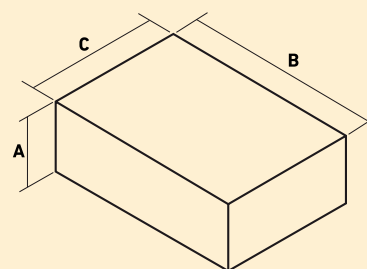

# Special electrodes



**Original**

high-end consumables line

# Fully customized!

Beside Standard and Saw Cut electrodes, GF Machining Solutions provides a specific service for tailored electrodes, machined according to your drawings and specifications.

## Orders

For orders please contact your Customer Services Consultant who will coordinate the entire ordering process with the production plant. In order to speed-up both quotation and production, we kindly ask you to provide all relevant information needed:

- + Technical drawings in CAD format
- + Dimensions
- + Tolerances
- + Surface finish
- + Quantity per electrode





# Metallic electrodes

Original

high-end consumables line

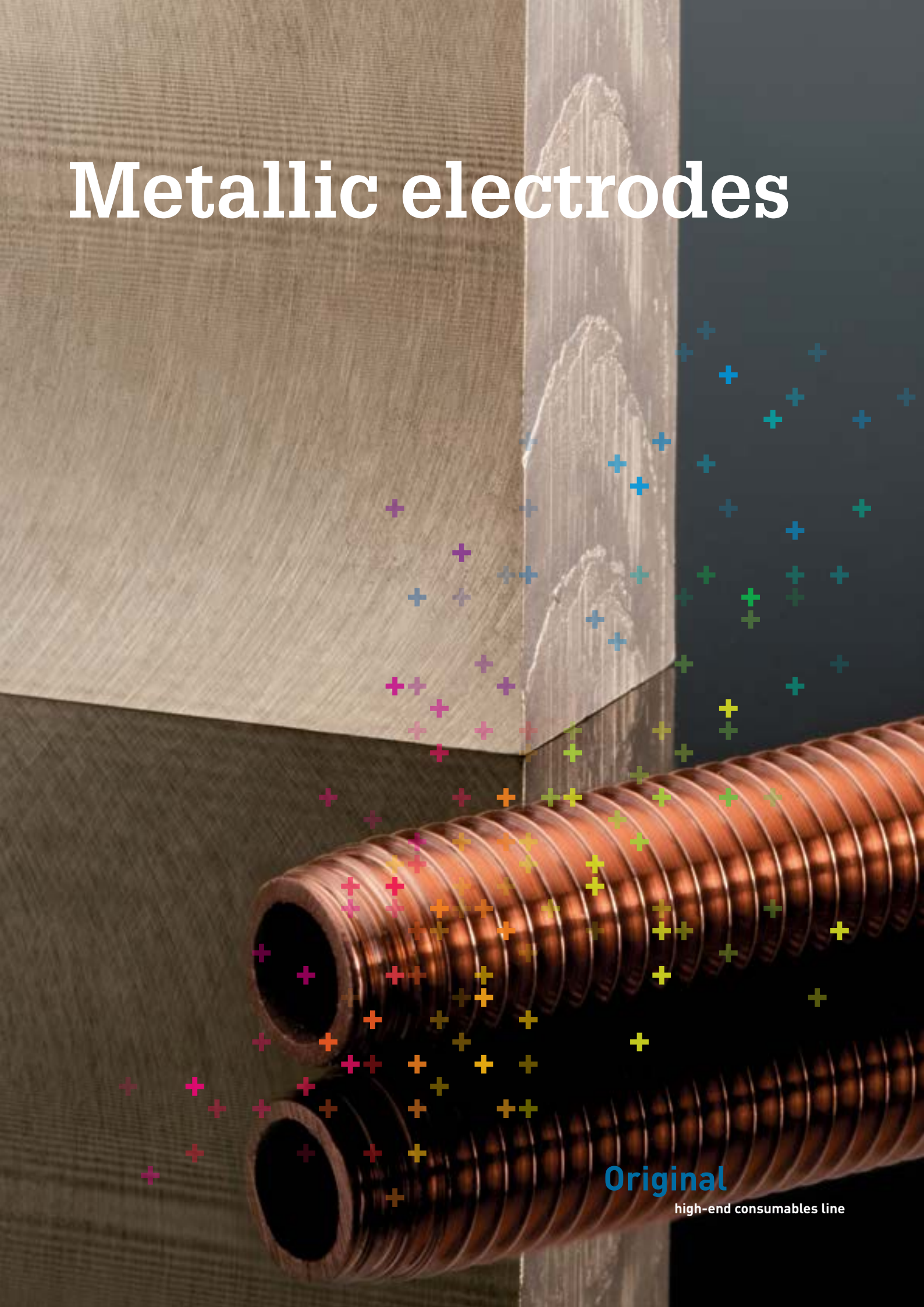



# Content

Copper	
Tapping electrodes orbital	106
Tapping electrodes not orbital	107
Standard cylinder electrodes	108
Standard plate electrodes	109
Standard square electrodes	111
Standard square for standard holder electrodes	112
Tungsten-copper (WCu)	
Tapping electrodes orbital	113
Tapping electrodes orbital without flushing hole	114
Tapping electrodes not orbital	115
Standard cylinder electrodes	116
Standard square electrodes	118
Standard plate electrodes	119
Standard sheet	120



# Copper

## Tapping electrodes orbital

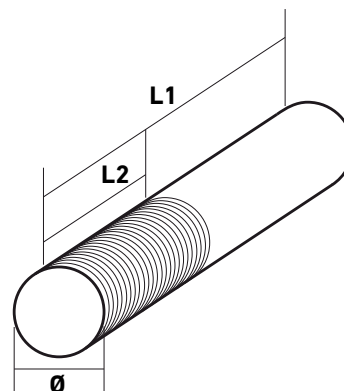

Reference	Diameter (mm)	Length L1 (mm)	Thread metric	Length thread L2 (mm)	Hole for flushing
951-351-003	2.3	80	M3 (0.50 mm)	50	Yes
951-351-004	2.9	80	M4 (0.70 mm)	50	Yes
951-351-005	3.8	120	M5 (0.80 mm)	80	Yes
951-351-006	4.5	120	M6 (1.00 mm)	80	Yes
951-351-008	6	120	M8 (1.25 mm)	80	Yes
951-351-010	7.8	120	M10 (1.50 mm)	80	Yes
951-351-012	9.4	120	M12 (1.75 mm)	80	Yes
951-351-014	11.1	120	M14 (2.00 mm)	80	Yes
951-351-016	13.1	120	M16 (2.00 mm)	80	Yes
951-351-018	14.4	120	M18 (2.50 mm)	80	Yes

# Copper

Tapping electrodes not orbital

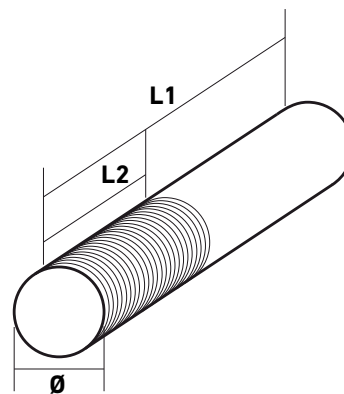

Reference	Diameter (mm)	Length L1 (mm)	Thread metric	Length thread L2 (mm)	Hole for flushing
951-350-003	2.9	80	M3 (0.50 mm)	50	Yes
951-350-004	3.9	80	M4 (0.70 mm)	50	Yes
951-350-005	4.9	120	M5 (0.80 mm)	80	Yes
951-350-006	5.9	120	M6 (1.00 mm)	80	Yes
951-350-008	7.9	120	M8 (1.25 mm)	80	Yes
951-350-010	9.9	120	M10 (1.50 mm)	80	Yes
951-350-012	11.8	120	M12 (1.75 mm)	80	Yes
951-350-014	13.8	120	M14 (2.00 mm)	80	Yes
951-350-016	15.8	120	M16 (2.00 mm)	80	Yes
951-350-018	17.8	120	M18 (2.50 mm)	80	Yes

# Copper

## Standard cylinder electrodes

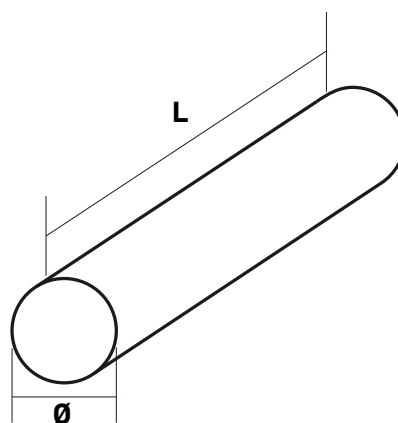

Reference	Diameter (mm)	Length (mm)	Tolerance (mm)	Quantity / Package
951-404-003	3	500	+0 / -0.06	1
951-404-004	4	500	+0 / -0.08	1
951-404-005	5	500	+0 / -0.08	1
951-404-006	6	500	+0 / -0.08	1
951-404-007	7	500	+0 / -0.09	1
951-404-008	8	500	+0 / -0.09	1
951-404-010	10	500	+0 / -0.09	1
951-404-012	12	500	+0 / -0.11	1
951-404-014	14	500	+0 / -0.11	1
951-404-015	15	500	+0 / -0.11	1
951-404-016	16	500	+0 / -0.11	1
951-404-018	18	500	+0 / -0.11	1
951-404-020	20	500	+0 / -0.19	1
951-404-025	25	500	+0 / -0.13	1
951-404-030	30	500	+0 / -0.13	1
951-404-032	32	500	+0 / -0.19	1
951-404-035	35	500	+0 / -0.19	1
951-404-040	40	500	+0 / -0.16	1
951-404-042	42	500	+0 / -0.16	1
951-404-050	50	500	+0 / -0.16	1
951-404-060	60	500	+0 / -0.19	1
951-404-080	80	500	+0 / -0.19	1
951-404-100	100	500	+0 / -0.19	1

# Copper

## Standard plate electrodes

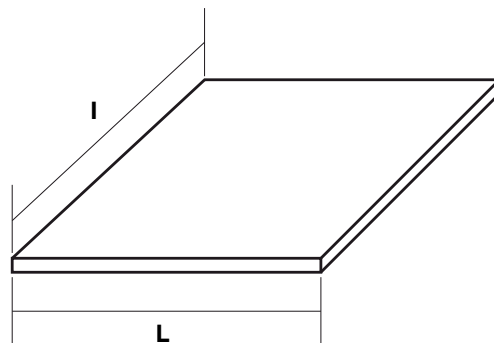
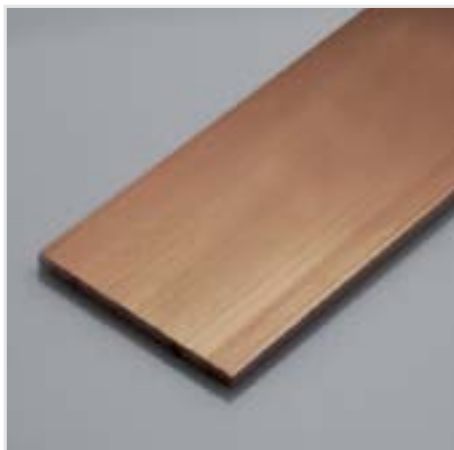

Reference	Length (mm)	Width (mm)	Thickness (mm)	Tolerance (mm)	Quantity / Package
951-405-020	500	20	2	-	1
951-405-021	500	25	2	-	1
951-405-022	500	30	2	-	1
951-405-030	500	10	3	-	1
951-405-031	500	15	3	-	1
951-405-032	500	20	3	-	1
951-405-033	500	25	3	-	1
951-405-034	500	40	3	-	1
951-405-040	500	10	4	-	1
951-405-041	500	15	4	-	1
951-405-042	500	20	4	-	1
951-405-043	500	25	4	-	1
951-405-050	500	10	5	-	1
951-405-051	500	15	5	-	1
951-405-052	500	20	5	-	1
951-405-053	500	25	5	-	1
951-405-054	500	35	5	-	1
951-405-055	500	40	5	-	1
951-405-056	500	60	5	-	1
951-405-057	500	80	5	-	1
951-405-058	500	100	5	-	1
951-405-060	500	20	6	-	1
951-405-061	500	40	6	-	1
951-405-062	500	60	6	-	1
951-405-063	500	80	6	-	1
951-405-064	500	100	6	-	1
951-405-080	500	20	8	-	1
951-405-081	500	25	8	-	1
951-405-082	500	40	8	-	1
951-405-083	500	60	8	-	1



# Copper

## Standard plate electrodes

Reference	Length (mm)	Width (mm)	Thickness (mm)	Tolerance (mm)	Quantity / Package
951-405-084	500	80	8	-	1
951-405-085	500	100	8	-	1
951-405-100	500	20	10	-	1
951-405-101	500	25	10	-	1
951-405-102	500	30	10	-	1
951-405-103	500	40	10	-	1
951-405-104	500	60	10	-	1
951-405-105	500	80	10	-	1
951-405-106	500	120	10	-	1
951-405-107	500	200	10	-	1
951-405-150	500	20	15	-	1
951-405-151	500	30	15	-	1
951-405-152	500	40	15	-	1
951-405-153	500	50	15	-	1
951-405-154	500	80	15	-	1
951-405-155	500	120	15	-	1
951-405-200	500	40	20	-	1
951-405-201	500	50	20	-	1
951-405-202	500	60	20	-	1
951-405-203	500	80	20	-	1
951-405-204	500	100	20	-	1
951-405-205	500	120	20	-	1
951-405-206	500	200	20	-	1
951-405-300	500	50	30	-	1
951-405-301	500	60	30	-	1
951-405-302	500	80	30	-	1
951-405-303	500	100	30	-	1
951-405-400	500	100	30	-	1
951-405-500	500	100	30	-	1



# Copper

## Standard square electrodes

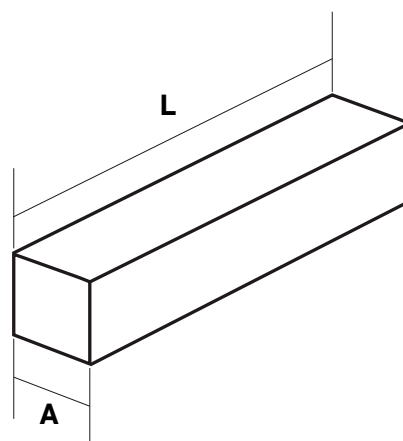

Reference	Size (mm)	Length (mm)	Tolerance (mm)	Quantity / Package
951-406-006	6 X 6	500	-	1
951-406-008	8 X 8	500	-	1
951-406-010	10 X 10	500	-	1
951-406-012	12 X 12	500	-	1
951-406-015	15 X 15	500	-	1
951-406-020	20 X 20	500	-	1
951-406-025	25 X 25	500	-	1
951-406-030	30 X 30	500	-	1
951-406-035	35 X 35	500	-	1
951-406-040	40 X 40	500	-	1
951-406-050	50 X 50	500	-	1

# Copper

Standard square electrodes for standard holder

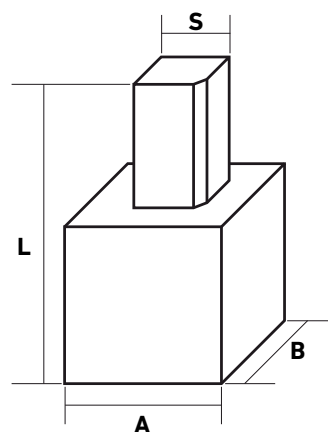

Reference	Length (mm)	Width (mm)	Thickness (mm)	Tolerance (mm)	Quantity / Package
951-407-015	75	15 X 15	-	-	40
951-407-025	90	25 X 25	-	-	24



# Tungsten-copper (WCu)

Tapping electrodes orbital

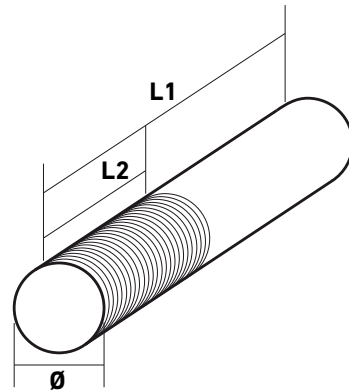

Reference	Diameter (mm)	Length L1 (mm)	Thread metric	Length thread L2 (mm)	Hole for flushing
951-352-003	2.3	80	M3 (0.50 mm)	50	Yes
951-352-004	2.9	80	M4 (0.70 mm)	50	Yes
951-352-005	3.8	80	M5 (0.80 mm)	50	Yes
951-352-006	4.5	80	M6 (1.00 mm)	50	Yes
951-352-008	6	80	M8 (1.25 mm)	50	Yes
951-352-010	7.8	80	M10 (1.50 mm)	50	Yes
951-352-012	9.4	80	M12 (1.75 mm)	50	Yes
951-352-014	11.1	80	M14 (2.00 mm)	50	Yes
951-352-016	13.1	80	M16 (2.00 mm)	50	Yes
951-352-018	14.4	80	M18 (2.50 mm)	50	Yes

# Tungsten-copper (Wcu)

Tapping electrodes orbital without flushing hole

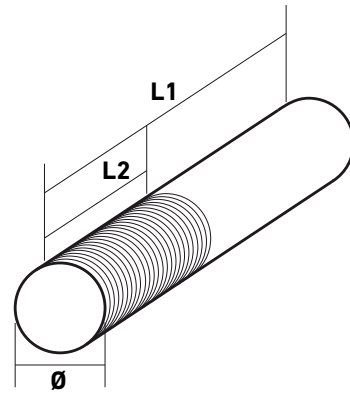

Reference	Diameter (mm)	Length L1 (mm)	Thread metric	Length thread L2 (mm)	Hole for flushing
951-354-001	1.4	80	M2 (0.40 mm)	50	No
951-354-002	1.8	80	M2.5 (0.45 mm)	50	No
951-354-003	2.3	80	M3 (0.50 mm)	50	No
951-354-004	2.9	80	M4 (0.70 mm)	50	No
951-354-005	3.8	80	M5 (0.80 mm)	50	No
951-354-006	4.5	80	M6 (1.00 mm)	50	No
951-354-008	6	80	M8 (1.25 mm)	50	No
951-354-010	7.8	80	M10 (1.50 mm)	50	No
951-354-012	9.4	80	M12 (1.75 mm)	50	No
951-354-014	11.1	80	M14 (2.00 mm)	50	No
951-354-016	13.1	80	M16 (2.00 mm)	50	No
951-354-018	14.1	80	M18 (2.50 mm)	50	No

# Tungsten-copper (Wcu)

Tapping electrodes not orbital

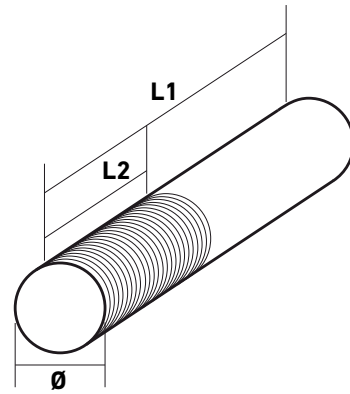

Reference	Diameter (mm)	Length L1 (mm)	Thread metric	Length thread L2 (mm)	Hole for flushing
951-353-003	2.9	80	M3 (0.50 mm)	50	Yes
951-353-004	3.9	80	M4 (0.70 mm)	50	Yes
951-353-005	4.9	80	M5 (0.80 mm)	50	Yes
951-353-006	5.9	80	M6 (1.00 mm)	50	Yes
951-353-008	7.9	80	M8 (1.25 mm)	50	Yes
951-353-010	9.9	80	M10 (1.50 mm)	50	Yes
951-353-012	11.8	80	M12 (1.75 mm)	50	Yes
951-353-014	13.8	80	M14 (2.00 mm)	50	Yes
951-353-016	15.8	80	M16 (2.00 mm)	50	Yes
951-353-018	17.8	80	M18 (2.50 mm)	50	Yes

# Tungsten-copper (Wcu)

Standard cylinder electrodes

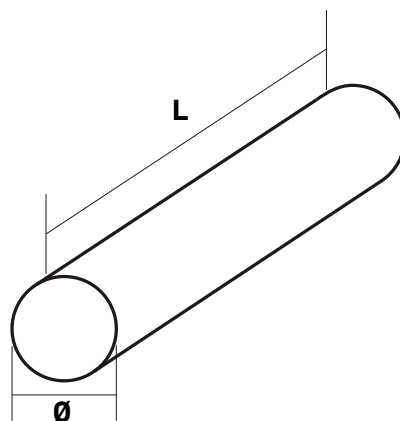

Reference	Diameter (mm)	Length (mm)	Tolerance (mm)	Quantity / Package
951-402-000	100	200		1
951-402-005	0.5	175	+/- 0.0125	1
951-402-006	0.6	175	+/- 0.0125	1
951-402-007	0.7	175	+/- 0.0125	1
951-402-008	0.8	175	+/- 0.0125	1
951-402-009	0.9	175	+/- 0.0125	1
951-402-010	1.0	175	+/- 0.0125	1
951-402-011	1.1	175	+/- 0.0125	1
951-402-012	1.2	175	+/- 0.0125	1
951-402-013	1.3	175	+/- 0.0125	1
951-402-014	1.4	175	+/- 0.0125	1
951-402-015	1.5	175	+/- 0.0125	1
951-402-016	1.6	175	+/- 0.0125	1
951-402-017	1.7	175	+/- 0.0125	1
951-402-018	1.8	175	+/- 0.0125	1
951-402-019	1.9	175	+/- 0.0125	1
951-402-020	2.0	175	+/- 0.0125	1
951-402-021	2.1	175	+/- 0.0125	1
951-402-022	2.2	175	+/- 0.0125	1
951-402-023	2.3	175	+/- 0.0125	1
951-402-024	2.4	175	+/- 0.0125	1
951-402-025	2.5	175	+/- 0.0125	1
951-402-026	2.6	175	+/- 0.0125	1
951-402-027	2.7	175	+/- 0.0125	1
951-402-028	2.8	175	+/- 0.0125	1
951-402-029	2.9	175	+/- 0.0125	1
951-402-030	3.0	175	+/- 0.0125	1
951-402-035	3.5	175	+/- 0.0125	1
951-402-040	4.0	175	+/- 0.0125	1



# Tungsten-copper (Wcu)

## Standard cylinder electrodes

Reference	Diameter (mm)	Length (mm)	Tolerance (mm)	Quantity / Package
951-402-045	4.5	175	+/- 0.0125	1
951-402-050	5.0	175	+/- 0.0125	1
951-402-055	5.5	175		1
951-402-060	6.0	200	+/- 0.05	1
951-402-065	6.5	200	+/- 0.1	1
951-402-080	8	200	+/- 0.1	1
951-402-100	10	200	+/- 0.1	1
951-402-120	12	200	+/- 0.1	1
951-402-125	125	200	+/- 0.1	1
951-402-140	14	200	+/- 0.1	1
951-402-150	150	200	+/- 0.1	1
951-402-160	16	200	+/- 0.1	1
951-402-200	20	200	+/- 0.1	1
951-402-250	25	200	+/- 0.1	1
951-402-300	30	200	+/- 0.1	1
951-402-350	35	200	+/- 0.15	1
951-402-370	70	30	+/- 0.15	1
951-402-380	80	30	+/- 0.15	1
951-402-390	90	30	+/- 0.15	1
951-402-400	40	200	+/- 0.15	1
951-402-500	50	200	+/- 0.15	1
951-402-600	65	200	+/- 0.15	1
951-402-610	60	200	+/- 0.15	1
951-402-660	60	60	+/- 0.15	1
951-402-670	70	60	+/- 0.15	1
951-402-680	80	60	+/- 0.15	1
951-402-690	90	60	+/- 0.15	1
951-402-700	75	200	+/- 0.15	1
951-402-800	16	100	+/- 0.15	1
951-402-801	20	100	+/- 0.1	1
951-402-802	25	100	+/- 0.1	1
951-402-803	30	100	+/- 0.1	1
951-402-804	35	100	+/- 0.15	1
951-402-805	40	100	+/- 0.15	1
951-402-806	50	100	+/- 0.15	1
951-402-807	50	50	+/- 0.15	1
951-402-808	60	30	+/- 0.15	1
951-402-900	90	200	+/- 0.15	1
951-402-951	1.0	175	+/- 0.0125	1
951-402-952	1.5	175	+/- 0.0125	1
951-402-953	2.0	175	+/- 0.0125	1
951-402-954	2.5	175	+/- 0.0125	1
951-402-955	3.0	175	+/- 0.0125	1



# Tungsten-copper (Wcu)

Standard square electrodes

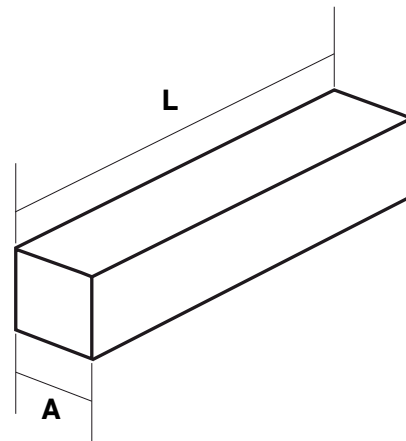

Reference	Size (mm)	Length (mm)	Tolerance (mm)	Quantity / Package
951-401-010	10 X 10	200	+/- 0.15	1
951-401-015	15 X 15	200	+/- 0.15	1
951-401-020	20 X 20	200	+/- 0.15	1
951-401-025	25 X 25	200	+/- 0.15	1
951-401-030	30 X 30	200	+/- 0.15	1
951-401-032	32 X 32	200	+/- 0.2	1
951-401-040	40 X 40	200	+/- 0.2	1

# Tungsten-copper (Wcu)

Standard plate electrodes

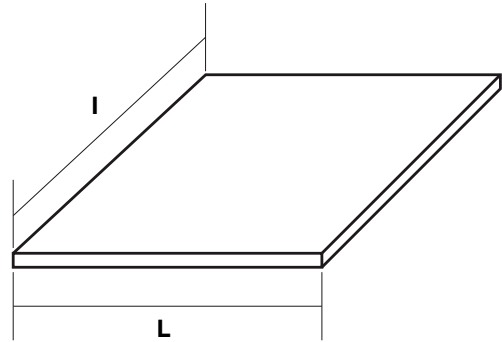
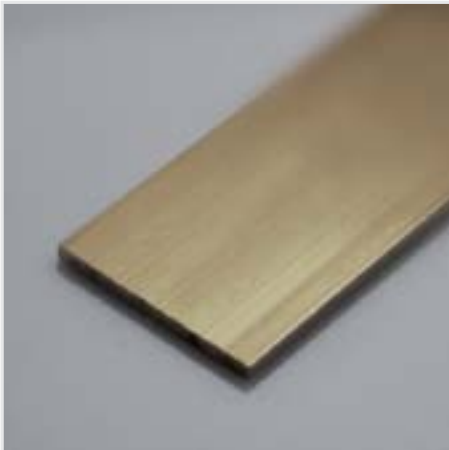

Reference	Length (mm)	Width (mm)	Thickness (mm)	Quantity / Package
951-400-030	200	75	3	1
951-400-040	200	75	4	1
951-400-050	200	75	5	1
951-400-051	200	75	5	1
951-400-060	200	75	6	1
951-400-061	200	75	6	1
951-400-080	200	75	8	1
951-400-100	200	75	10	1
951-400-101	200	75	10	1
951-400-120	200	75	12	1
951-400-121	200	75	12	1
951-400-150	200	75	15	1
951-400-151	200	75	15	1
951-400-200	200	75	20	1
951-400-201	200	75	20	1
951-400-250	200	75	25	1
951-400-251	200	75	25	1
951-400-500	200	75	50	1

# Tungsten-copper (Wcu)

## Standard Sheet

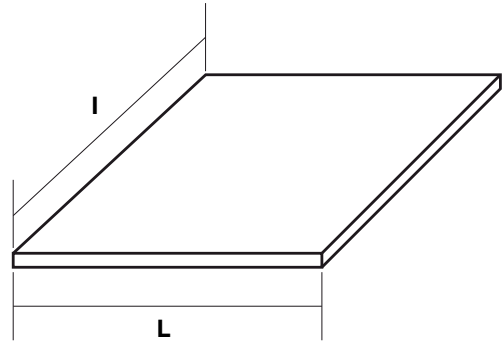

Reference	Dimensions (mm)	Toleranz (mm)	I x L (mm)
951-403-010	0,102	+/-0,005	25 x 203
951-403-012	0,127		25 x 203
951-403-015	0,152	+/-0,008	25 x 203
951-403-017	0,178		25 x 203
951-403-020	0,203	+/-0,013	25 x 203
951-403-022	0,229		25 x 203
951-403-025	0,254		25 x 203
951-403-027	0,279		25 x 203
951-403-030	0,305	+/-0,013	25 x 203
951-403-033	0,330		25 x 203
951-403-035	0,356		25 x 203
951-403-038	0,381	+/-0,051	76 x 203
951-403-050	0,508	+/-0,051	76 x 203
951-403-063	0,635	+/-0,051	76 x 203
951-403-076	0,762	+/-0,051	76 x 203
951-403-088	0,889	+/-0,102	76 x 203
951-403-101	1,016	+/-0,102	76 x 203
951-403-114	1,143		76 x 203
951-403-127	1,270		76 x 203
951-403-152	1,524	+/-0,127	76 x 203
951-403-200	2,000	+/-0,127	76 x 203





# Drilling electrodes



**Original**

high-end consumables line

# Content

Start hole tubes	
Copper / L 300 mm	124
Copper/ L 400 mm	125
Brass / L 300 mm	126
Brass / L 400 mm	127
Carbide / 154 mm	128
Carbide / L 320 mm	129
Copper multichannel / L 300 mm	130
Brass multichannel / L 300 mm	131
Brass multichannel / L 400 mm	132
Tungsten-copper (Wcu) / L 175 mm	133
Multichannel tubes "Coreless"	
Copper / L 150 mm	134
Copper / L 300 mm	136
Standard tubes	
Copper / L 150 mm	138
Copper / L 300 mm	141
Carbide / L 150 mm	144
Carbide / L 300 mm	146
Start hole tube guides	
Configuration recommendations with the 'non' insulated guide support plate	147
Configuration recommendations with insulated guide support plate	148
Insulated guide support plate, adjustable	149
Electrode support	150
Guide support simple, insulated + not insulated	151
Double guide support, insulated + not insulated	151
Standard guides, single or kit	152
Ceramic guide - precision guide	153
Carbide guide – precision guide	154

# Start hole tubes

Copper / L 300 mm



Reference	Outside diameter (mm)	Length (mm)	Tolerance (mm)	Quantity / Package
951-303-002	0.20	300	+0 / -0.02	10
951-303-003	0.30	300	+0 / -0.02	10
951-303-004	0.40	300	+0 / -0.02	10
951-303-005	0.50	300	+0 / -0.02	10
951-303-006	0.60	300	+0 / -0.02	10
951-303-007	0.70	300	+0 / -0.02	10
951-303-008	0.80	300	+0 / -0.02	10
951-303-009	0.90	300	+0 / -0.02	10
951-303-010	1.00	300	+0 / -0.02	10
951-303-011	1.10	300	+0 / -0.02	10
951-303-012	1.20	300	+0 / -0.02	10
951-303-013	1.30	300	+0 / -0.02	10
951-303-014	1.40	300	+0 / -0.02	10
951-303-015	1.50	300	+0 / -0.02	10
951-303-016	1.60	300	+0 / -0.02	10
951-303-017	1.70	300	+0 / -0.02	10
951-303-018	1.80	300	+0 / -0.02	10
951-303-019	1.90	300	+0 / -0.02	10
951-303-020	2.00	300	+0 / -0.02	10
951-303-021	2.10	300	+0 / -0.03	10
951-303-022	2.20	300	+0 / -0.03	10
951-303-023	2.30	300	+0 / -0.03	10
951-303-024	2.40	300	+0 / -0.03	10
951-303-025	2.50	300	+0 / -0.03	10
951-303-026	2.60	300	+0 / -0.03	10
951-303-027	2.70	300	+0 / -0.03	10
951-303-028	2.80	300	+0 / -0.03	10
951-303-029	2.90	300	+0 / -0.03	10
951-303-030	3.00	300	+0 / -0.03	10

# Start hole tubes

Copper / L 400 mm



Reference	Outside diameter (mm)	Length (mm)	Tolerance (mm)	Quantity / Package
951-314-003	0.3	400	+0 / -0.02	10
951-314-004	0.4	400	+0 / -0.02	10
951-314-005	0.5	400	+0 / -0.02	10
951-314-006	0.6	400	+0 / -0.02	10
951-314-007	0.7	400	+0 / -0.02	10
951-314-008	0.8	400	+0 / -0.02	10
951-314-009	0.9	400	+0 / -0.02	10
951-314-010	1.0	400	+0 / -0.02	10
951-314-011	1.1	400	+0 / -0.02	10
951-314-012	1.2	400	+0 / -0.02	10
951-314-013	1.3	400	+0 / -0.02	10
951-314-014	1.4	400	+0 / -0.02	10
951-314-015	1.5	400	+0 / -0.02	10
951-314-016	1.6	400	+0 / -0.02	10
951-314-017	1.7	400	+0 / -0.02	10
951-314-018	1.8	400	+0 / -0.02	10
951-314-019	1.9	400	+0 / -0.02	10
951-314-020	2.0	400	+0 / -0.02	10
951-314-021	2.1	400	+0 / -0.03	10
951-314-022	2.2	400	+0 / -0.03	10
951-314-023	2.3	400	+0 / -0.03	10
951-314-024	2.4	400	+0 / -0.03	10
951-314-025	2.5	400	+0 / -0.03	10
951-314-026	2.6	400	+0 / -0.03	10
951-314-027	2.7	400	+0 / -0.03	10
951-314-028	2.8	400	+0 / -0.03	10
951-314-029	2.9	400	+0 / -0.03	10
951-314-030	3.0	400	+0 / -0.03	10

# Start hole tubes

Brass/ L 300 mm



Reference	Outside diameter (mm)	Length (mm)	Tolerance (mm)	Quantity / Package
951-306-001	0.15	300	+0 / -0.02	10
951-306-002	0.20	300	+0 / -0.02	10
951-306-003	0.30	300	+0 / -0.02	10
951-306-004	0.40	300	+0 / -0.02	10
951-306-005	0.50	300	+0 / -0.02	10
951-306-006	0.60	300	+0 / -0.02	10
951-306-007	0.70	300	+0 / -0.02	10
951-306-008	0.80	300	+0 / -0.02	10
951-306-009	0.90	300	+0 / -0.02	10
951-306-010	1.00	300	+0 / -0.02	10
951-306-011	1.10	300	+0 / -0.02	10
951-306-012	1.20	300	+0 / -0.02	10
951-306-013	1.30	300	+0 / -0.02	10
951-306-014	1.40	300	+0 / -0.02	10
951-306-015	1.50	300	+0 / -0.02	10
951-306-016	1.60	300	+0 / -0.02	10
951-306-017	1.70	300	+0 / -0.02	10
951-306-018	1.80	300	+0 / -0.02	10
951-306-019	1.90	300	+0 / -0.02	10
951-306-020	2.00	300	+0 / -0.02	10
951-306-021	2.10	300	+0 / -0.02	10
951-306-022	2.20	300	+0 / -0.02	10
951-306-023	2.30	300	+0 / -0.02	10
951-306-024	2.40	300	+0 / -0.02	10
951-306-025	2.50	300	+0 / -0.02	10
951-306-030	3.00	300	+0 / -0.02	10
951-306-040	4.00	300	+0 / -0.02	10
951-306-060	6.00	300	+0 / -0.02	10

# Start hole tubes

Brass / L 400 mm



Reference	Outside diameter (mm)	Length (mm)	Tolerance (mm)	Quantity / Package
951-307-003	0.30	400	+0 / -0.02	10
951-307-004	0.40	400	+0 / -0.02	10
951-307-005	0.50	400	+0 / -0.02	10
951-307-006	0.60	400	+0 / -0.02	10
951-307-007	0.70	400	+0 / -0.02	10
951-307-008	0.80	400	+0 / -0.02	10
951-307-009	0.90	400	+0 / -0.02	10
951-307-010	1.00	400	+0 / -0.02	10
951-307-011	1.10	400	+0 / -0.02	10
951-307-012	1.20	400	+0 / -0.02	10
951-307-013	1.30	400	+0 / -0.02	10
951-307-014	1.40	400	+0 / -0.02	10
951-307-015	1.50	400	+0 / -0.02	10
951-307-016	1.60	400	+0 / -0.02	10
951-307-017	1.70	400	+0 / -0.02	10
951-307-018	1.80	400	+0 / -0.02	10
951-307-019	1.90	400	+0 / -0.02	10
951-307-020	2.00	400	+0 / -0.02	10
951-307-021	2.10	400	+0 / -0.02	10
951-307-022	2.20	400	+0 / -0.02	10
951-307-023	2.30	400	+0 / -0.02	10
951-307-024	2.40	400	+0 / -0.02	10
951-307-025	2.50	400	+0 / -0.02	10
951-307-026	2.60	400	+0 / -0.02	10
951-307-027	2.70	400	+0 / -0.02	10
951-307-028	2.80	400	+0 / -0.02	10
951-307-029	2.90	400	+0 / -0.02	10
951-307-030	3.00	400	+0 / -0.02	10

# Start hole tubes

Carbide / L 154 mm



Reference	Outside diameter (mm)	Length (mm)	Tolerance (mm)	Quantity / Package
951-310-103	0.3	154	+0 / -0.06	10
951-310-104	0.4	154	+0 / -0.06	10
951-310-105	0.5	154	+0 / -0.06	10
951-310-106	0.6	154	+0 / -0.06	10
951-310-107	0.7	154	+0 / -0.06	10
951-310-108	0.8	154	+0 / -0.06	10
951-310-109	0.9	154	+0 / -0.06	10
951-310-110	1	154	+0 / -0.06	10
951-310-111	1.1	154	+0 / -0.06	10
951-310-112	1.2	154	+0 / -0.06	10
951-310-113	1.3	154	+0 / -0.06	10
951-310-114	1.4	154	+0 / -0.06	10
951-310-115	1.5	154	+0 / -0.06	10
951-310-120	2	154	+0 / -0.06	10
951-310-125	2.5	154	+0 / -0.06	10
951-310-130	3	154	+0 / -0.06	10
951-310-135	3.5	154	+0 / -0.06	10
951-310-140	4	154	+0 / -0.06	10
951-310-145	4.5	154	+0 / -0.06	10
951-310-150	5	154	+0 / -0.06	10
951-310-155	5.5	154	+0 / -0.06	10
951-310-160	6	154	+0 / -0.06	10



# Start hole tubes

Carbide / L 320 mm



Reference	Outside diameter (mm)	Length (mm)	Tolerance (mm)	Quantity / Package
951-311-105	0.5	320	+0 / -0.06	10
951-311-106	0.6	320	+0 / -0.06	10
951-311-107	0.7	320	+0 / -0.06	10
951-311-108	0.8	320	+0 / -0.06	10
951-311-109	0.9	320	+0 / -0.06	10
951-311-110	1	320	+0 / -0.06	10
951-311-111	1.1	320	+0 / -0.06	10
951-311-112	1.2	320	+0 / -0.06	10
951-311-113	1.3	320	+0 / -0.06	10
951-311-114	1.4	320	+0 / -0.06	10
951-311-115	1.5	320	+0 / -0.06	10
951-311-120	2	320	+0 / -0.06	10
951-311-130	3	320	+0 / -0.06	10

# Start hole tubes

Copper multichannel / L 300 mm



## Inner form

⊕ Diameter 0,6 ÷ 2,0

Reference	Outside diameter (mm)	Length (mm)	Tolerance (mm)	Quantity / Package
951-302-002	0.20	300	+0 / -0.02	10
951-302-003	0.30	300	+0 / -0.02	10
951-302-004	0.40	300	+0 / -0.02	10
951-302-005	0.50	300	+0 / -0.02	10
951-302-006	0.60	300	+0 / -0.02	10
951-302-007	0.70	300	+0 / -0.02	10
951-302-008	0.80	300	+0 / -0.02	10
951-302-009	0.90	300	+0 / -0.02	10
951-302-010	1.00	300	+0 / -0.02	10
951-302-011	1.10	300	+0 / -0.03	10
951-302-012	1.20	300	+0 / -0.03	10
951-302-013	1.30	300	+0 / -0.03	10
951-302-014	1.40	300	+0 / -0.03	10
951-302-015	1.50	300	+0 / -0.03	10
951-302-016	1.60	300	+0 / -0.03	10
951-302-017	1.70	300	+0 / -0.03	10
951-302-018	1.80	300	+0 / -0.03	10
951-302-019	1.90	300	+0 / -0.03	10
951-302-020	2.00	300	+0 / -0.03	10
951-302-021	2.10	300	+0 / -0.03	10
951-302-022	2.20	300	+0 / -0.03	10
951-302-023	2.30	300	+0 / -0.03	10
951-302-024	2.40	300	+0 / -0.03	10
951-302-025	2.50	300	+0 / -0.03	10
951-302-026	2.60	300	+0 / -0.03	10
951-302-027	2.70	300	+0 / -0.03	10
951-302-028	2.80	300	+0 / -0.03	10
951-302-029	2.90	300	+0 / -0.03	10
951-302-030	3.00	300	+0 / -0.03	10

# Start hole tubes

Brass multichannel / L 300 mm



## Inner form

 Diameter 0,8 ÷ 3,0

 Diameter 3,1 ÷ 4,0

Reference	Outside diameter (mm)	Length (mm)	Tolerance (mm)	Quantity / Package
951-308-007	0.70	300	+0 / -0.02	10
951-308-008	0.80	300	+0 / -0.02	10
951-308-009	0.90	300	+0 / -0.02	10
951-308-010	1.00	300	+0 / -0.02	10
951-308-011	1.10	300	+0 / -0.02	10
951-308-012	1.20	300	+0 / -0.02	10
951-308-013	1.30	300	+0 / -0.02	10
951-308-014	1.40	300	+0 / -0.02	10
951-308-015	1.50	300	+0 / -0.02	10
951-308-016	1.60	300	+0 / -0.02	10
951-308-017	1.70	300	+0 / -0.02	10
951-308-018	1.80	300	+0 / -0.02	10
951-308-019	1.90	300	+0 / -0.02	10
951-308-020	2.00	300	+0 / -0.02	10
951-308-021	2.10	300	+0 / -0.02	10
951-308-022	2.20	300	+0 / -0.02	10
951-308-023	2.30	300	+0 / -0.02	10
951-308-024	2.40	300	+0 / -0.02	10
951-308-025	2.50	300	+0 / -0.02	10
951-308-026	2.60	300	+0 / -0.02	10
951-308-027	2.70	300	+0 / -0.02	10
951-308-028	2.80	300	+0 / -0.02	10
951-308-029	2.90	300	+0 / -0.02	10
951-308-030	3.00	300	+0 / -0.02	10
951-308-031	3.10	300	+0 / -0.02	10
951-308-032	3.20	300	+0 / -0.02	10
951-308-033	3.20	300	+0 / -0.02	10
951-308-034	3.40	300	+0 / -0.02	10
951-308-035	3.50	300	+0 / -0.02	10
951-308-036	3.60	300	+0 / -0.02	10
951-308-037	3.70	300	+0 / -0.02	10
951-308-038	3.80	300	+0 / -0.02	10
951-308-039	3.90	300	+0 / -0.02	10
951-308-040	4.00	300	+0 / -0.02	10

# Start hole tubes

Brass multichannel / L 400 mm



## Inner form

 Diameter 0,5 ÷ 3,0

Reference	Outside diameter (mm)	Length (mm)	Tolerance (mm)	Quantity / Package
951-315-005	0.50	400	+0 / -0.02	10
951-315-007	0.70	400	+0 / -0.02	10
951-315-008	0.80	400	+0 / -0.02	10
951-315-009	0.90	400	+0 / -0.02	10
951-315-010	1.00	400	+0 / -0.02	10
951-315-012	1.20	400	+0 / -0.02	10
951-315-015	1.50	400	+0 / -0.02	10
951-315-018	1.80	400	+0 / -0.02	10
951-315-020	2.00	400	+0 / -0.02	10
951-315-025	2.50	400	+0 / -0.02	10
951-315-028	2.80	400	+0 / -0.02	10
951-315-030	3.00	400	+0 / -0.02	10
951-315-037	3.70	400	+0 / -0.02	10
951-315-038	3.80	400	+0 / -0.02	10
951-315-040	4.00	400	+0 / -0.02	10
951-315-043	4.30	400	+0 / -0.02	10
951-315-048	4.80	400	+0 / -0.02	10
951-315-050	5.00	400	+0 / -0.02	10
951-315-060	6.00	400	+0 / -0.02	10

# Start hole tubes

Tungsten-copper(WCu) / L 175 mm







Reference	Outside diameter (mm)	Length (mm)	Tolerance (mm)	Quantity / Package
951-309-107	0.70	175	+0.01 / -0.01	10
951-309-108	0.80	175	+0.01 / -0.01	10
951-309-109	0.90	175	+0.01 / -0.01	10
951-309-110	1.00	175	+0.01 / -0.01	10
951-309-111	1.10	175	+0.01 / -0.01	10
951-309-112	1.20	175	+0.01 / -0.01	10
951-309-113	1.30	175	+0.01 / -0.01	10
951-309-114	1.40	175	+0.01 / -0.01	10
951-309-115	1.50	175	+0.01 / -0.01	10
951-309-116	1.60	175	+0.01 / -0.01	10
951-309-117	1.70	175	+0.01 / -0.01	10
951-309-118	1.80	175	+0.01 / -0.01	10
951-309-119	1.90	175	+0.01 / -0.01	10
951-309-120	2.00	175	+0.01 / -0.01	10
951-309-121	2.10	175	+0.01 / -0.01	10
951-309-122	2.20	175	+0.01 / -0.01	10
951-309-123	2.30	175	+0.01 / -0.01	10
951-309-124	2.40	175	+0.01 / -0.01	10
951-309-125	2.50	175	+0.01 / -0.01	10
951-309-126	2.60	175	+0.01 / -0.01	10
951-309-127	2.70	175	+0.01 / -0.01	10
951-309-128	2.80	175	+0.01 / -0.01	10
951-309-129	2.90	175	+0.01 / -0.01	10
951-309-130	3.00	175	+0.01 / -0.01	10
951-309-135	3.50	175	+0.01 / -0.01	10
951-309-140	4.00	175	+0.01 / -0.01	10
951-309-145	4.50	175	+0.01 / -0.01	10
951-309-150	5.00	175	+0.01 / -0.01	10

# Multichannel tubes “Coreless”

Copper / L 150 mm



## Inner form

-  Diameter  $\leq 0,4$
-  Diameter  $0,5 \div 1,5$
-  Diameter  $1,6 \div 4,0$
-  Diameter  $4,1 \div 4,9$
-  Diameter  $5,0 \div 12,0$

Reference	Outside diameter [mm]	Length [mm]	Tolerance [mm]	Number of channels	Quantity / Package
951-300-003	0.30	150	+0 / -0.02	2 (1 bar inserted)	10
951-300-004	0.40	150	+0 / -0.02	2 (Wires inserted)	10
951-300-005	0.50	150	+0 / -0.02	2 (Wires inserted)	10
951-300-006	0.60	150	+0 / -0.02	2 (Wires inserted)	10
951-300-007	0.70	150	+0 / -0.02	2 (Wires inserted)	10
951-300-008	0.80	150	+0 / -0.02	2 (Wires inserted)	10
951-300-009	0.90	150	+0 / -0.02	2 (Wires inserted)	10
951-300-010	1.00	150	+0 / -0.02	2 (Wires inserted)	10
951-300-011	1.10	150	+0 / -0.02	2 (Wires inserted)	10
951-300-012	1.20	150	+0 / -0.02	2 (Wires inserted)	10
951-300-013	1.30	150	+0 / -0.02	2 (Wires inserted)	10
951-300-014	1.40	150	+0 / -0.02	2 (Wires inserted)	10
951-300-015	1.50	150	+0 / -0.02	2 (Wires inserted)	10
951-300-016	1.60	150	+0 / -0.02	2 (Tubes inserted)	10
951-300-017	1.70	150	+0 / -0.02	2 (Tubes inserted)	10
951-300-018	1.80	150	+0 / -0.02	2 (Tubes inserted)	10
951-300-019	1.90	150	+0 / -0.02	2 (Tubes inserted)	10
951-300-020	2.00	150	+0 / -0.02	2 (Tubes inserted)	10
951-300-021	2.10	150	+0 / -0.03	2 (Tubes inserted)	10
951-300-022	2.20	150	+0 / -0.03	2 (Tubes inserted)	10
951-300-023	2.30	150	+0 / -0.03	2 (Tubes inserted)	10
951-300-024	2.40	150	+0 / -0.03	2 (Tubes inserted)	10
951-300-025	2.50	150	+0 / -0.03	2 (Tubes inserted)	10
951-300-026	2.60	150	+0 / -0.03	2 (Tubes inserted)	10
951-300-027	2.70	150	+0 / -0.03	2 (Tubes inserted)	10
951-300-028	2.80	150	+0 / -0.03	2 (Tubes inserted)	10
951-300-029	2.90	150	+0 / -0.03	2 (Tubes inserted)	10
951-300-030	3.00	150	+0 / -0.03	2 (Tubes inserted)	10
951-300-031	3.10	150	+0 / -0.03	2 (Tubes inserted)	10



# Multichannel tubes “Coreless”

Copper / L 150 mm

Reference	Outside diameter (mm)	Length (mm)	Tolerance (mm)	Number of channels	Quantity / Package
951-300-032	3.20	150	+0 / -0.03	2 (Tubes inserted)	10
951-300-033	3.30	150	+0 / -0.03	2 (Tubes inserted)	10
951-300-034	3.40	150	+0 / -0.03	2 (Tubes inserted)	10
951-300-035	3.50	150	+0 / -0.03	2 (Tubes inserted)	10
951-300-036	3.60	150	+0 / -0.03	2 (Tubes inserted)	10
951-300-037	3.70	150	+0 / -0.03	2 (Tubes inserted)	10
951-300-038	3.80	150	+0 / -0.03	2 (Tubes inserted)	10
951-300-039	3.90	150	+0 / -0.03	2 (Tubes inserted)	10
951-300-040	4.00	150	+0 / -0.04	2 (Tubes inserted)	10
951-300-041	4.10	150	+0 / -0.04	2 (Wires inserted)	10
951-300-042	4.20	150	+0 / -0.04	2 (Wires inserted)	10
951-300-043	4.30	150	+0 / -0.04	2 (Wires inserted)	10
951-300-044	4.40	150	+0 / -0.04	2 (Wires inserted)	10
951-300-045	4.50	150	+0 / -0.04	2 (Wires inserted)	10
951-300-046	4.60	150	+0 / -0.04	2 (Wires inserted)	10
951-300-047	4.70	150	+0 / -0.04	2 (Wires inserted)	10
951-300-048	4.80	150	+0 / -0.04	2 (Wires inserted)	10
951-300-049	4.90	150	+0 / -0.04	2 (Wires inserted)	10
951-300-050	5.00	150	+0 / -0.04	3 (Wires inserted)	10
951-300-051	5.10	150	+0 / -0.04	3 (Wires inserted)	10
951-300-052	5.20	150	+0 / -0.04	3 (Wires inserted)	10
951-300-053	5.30	150	+0 / -0.04	3 (Wires inserted)	10
951-300-054	5.40	150	+0 / -0.04	3 (Wires inserted)	10
951-300-055	5.50	150	+0 / -0.04	3 (Wires inserted)	10
951-300-056	5.60	150	+0 / -0.04	3 (Wires inserted)	10
951-300-057	5.70	150	+0 / -0.04	3 (Wires inserted)	10
951-300-058	5.80	150	+0 / -0.04	3 (Wires inserted)	10
951-300-059	5.90	150	+0 / -0.04	3 (Wires inserted)	10
951-300-060	6.00	150	+0 / -0.04	3 (Wires inserted)	5
951-300-065	6.50	150	+0 / -0.04	3 (Wires inserted)	5
951-300-070	7.00	150	+0 / -0.04	3 (Wires inserted)	5
951-300-075	7.50	150	+0 / -0.04	3 (Wires inserted)	5
951-300-080	8.00	150	+0 / -0.04	3 (Wires inserted)	5
951-300-085	8.50	150	+0 / -0.04	3 (Wires inserted)	5
951-300-090	9.00	150	+0 / -0.04	3 (Wires inserted)	5
951-300-095	9.50	150	+0 / -0.04	3 (Wires inserted)	5
951-300-100	10.00	150	+0 / -0.04	3 (Wires inserted)	1
951-300-105	10.50	150	+0 / -0.04	3 (Wires inserted)	1
951-300-110	11.00	150	+0 / -0.04	3 (Wires inserted)	1
951-300-115	11.50	150	+0 / -0.04	3 (Wires inserted)	1
951-300-120	12.00	150	+0 / -0.04	3 (Wires inserted)	1







# Multichannel tubes “Coreless”

Copper / L 300 mm



## Inner form

-  Diameter  $\leq 0,4$
-  Diameter  $0,5 \div 1,5$
-  Diameter  $1,6 \div 4,0$
-  Diameter  $4,1 \div 4,9$
-  Diameter  $5,0 \div 12,0$

Reference	Outside diameter (mm)	Length (mm)	Tolerance (mm)	Number of channels	Quantity / Package
951-301-003	0.30	300	+0 / -0.02	2 (1 bar inserted)	10
951-301-004	0.40	300	+0 / -0.02	2 (Wires inserted)	10
951-301-005	0.50	300	+0 / -0.02	2 (Wires inserted)	10
951-301-006	0.60	300	+0 / -0.02	2 (Wires inserted)	10
951-301-007	0.70	300	+0 / -0.02	2 (Wires inserted)	10
951-301-008	0.80	300	+0 / -0.02	2 (Wires inserted)	10
951-301-009	0.90	300	+0 / -0.02	2 (Wires inserted)	10
951-301-010	1.00	300	+0 / -0.02	2 (Wires inserted)	10
951-301-011	1.10	300	+0 / -0.02	2 (Wires inserted)	10
951-301-012	1.20	300	+0 / -0.02	2 (Wires inserted)	10
951-301-013	1.30	300	+0 / -0.02	2 (Wires inserted)	10
951-301-014	1.40	300	+0 / -0.02	2 (Wires inserted)	10
951-301-015	1.50	300	+0 / -0.02	2 (Wires inserted)	10
951-301-016	1.60	300	+0 / -0.02	2 (Tubes inserted)	10
951-301-017	1.70	300	+0 / -0.02	2 (Tubes inserted)	10
951-301-018	1.80	300	+0 / -0.02	2 (Tubes inserted)	10
951-301-019	1.90	300	+0 / -0.02	2 (Tubes inserted)	10
951-301-020	2.00	300	+0 / -0.02	2 (Tubes inserted)	10
951-301-021	2.10	300	+0 / -0.03	2 (Tubes inserted)	10
951-301-022	2.20	300	+0 / -0.03	2 (Tubes inserted)	10
951-301-023	2.30	300	+0 / -0.03	2 (Tubes inserted)	10
951-301-024	2.40	300	+0 / -0.03	2 (Tubes inserted)	10
951-301-025	2.50	300	+0 / -0.03	2 (Tubes inserted)	10
951-301-026	2.60	300	+0 / -0.03	2 (Tubes inserted)	10
951-301-027	2.70	300	+0 / -0.03	2 (Tubes inserted)	10
951-301-028	2.80	300	+0 / -0.03	2 (Tubes inserted)	10
951-301-029	2.90	300	+0 / -0.03	2 (Tubes inserted)	10
951-301-030	3.00	300	+0 / -0.03	2 (Tubes inserted)	10
951-301-031	3.10	300	+0 / -0.03	2 (Tubes inserted)	10





# Multichannel tubes “Coreless”

Copper / L 300 mm

Reference	Outside diameter (mm)	Length (mm)	Tolerance (mm)	Number of channels	Quantity / Package
951-301-032	3.20	300	+0 / -0.03	2 (Tubes inserted)	10
951-301-033	3.30	300	+0 / -0.03	2 (Tubes inserted)	10
951-301-034	3.40	300	+0 / -0.03	2 (Tubes inserted)	10
951-301-035	3.50	300	+0 / -0.03	2 (Tubes inserted)	10
951-301-036	3.60	300	+0 / -0.03	2 (Tubes inserted)	10
951-301-037	3.70	300	+0 / -0.03	2 (Tubes inserted)	10
951-301-038	3.80	300	+0 / -0.03	2 (Tubes inserted)	10
951-301-039	3.90	300	+0 / -0.03	2 (Tubes inserted)	10
951-301-040	4.00	300	+0 / -0.04	2 (Tubes inserted)	10
951-301-041	4.10	300	+0 / -0.04	2 (Wires inserted)	10
951-301-042	4.20	300	+0 / -0.04	2 (Wires inserted)	10
951-301-043	4.30	300	+0 / -0.04	2 (Wires inserted)	10
951-301-044	4.40	300	+0 / -0.04	2 (Wires inserted)	10
951-301-045	4.50	300	+0 / -0.04	2 (Wires inserted)	10
951-301-046	4.60	300	+0 / -0.04	2 (Wires inserted)	10
951-301-047	4.70	300	+0 / -0.04	2 (Wires inserted)	10
951-301-048	4.80	300	+0 / -0.04	2 (Wires inserted)	10
951-301-049	4.90	300	+0 / -0.04	2 (Wires inserted)	10
951-301-050	5.00	300	+0 / -0.04	3 (Wires inserted)	10
951-301-051	5.10	300	+0 / -0.04	3 (Wires inserted)	10
951-301-052	5.20	300	+0 / -0.04	3 (Wires inserted)	10
951-301-053	5.30	300	+0 / -0.04	3 (Wires inserted)	10
951-301-054	5.40	300	+0 / -0.04	3 (Wires inserted)	10
951-301-055	5.50	300	+0 / -0.04	3 (Wires inserted)	10
951-301-056	5.60	300	+0 / -0.04	3 (Wires inserted)	10
951-301-057	5.70	300	+0 / -0.04	3 (Wires inserted)	10
951-301-058	5.80	300	+0 / -0.04	3 (Wires inserted)	10
951-301-059	5.90	300	+0 / -0.04	3 (Wires inserted)	10
951-301-060	6.00	300	+0 / -0.04	3 (Wires inserted)	5
951-301-065	6.50	300	+0 / -0.04	3 (Wires inserted)	5
951-301-070	7.00	300	+0 / -0.04	3 (Wires inserted)	5
951-301-075	7.50	300	+0 / -0.04	3 (Wires inserted)	5
951-301-080	8.00	300	+0 / -0.04	3 (Wires inserted)	5
951-301-085	8.50	300	+0 / -0.04	3 (Wires inserted)	5
951-301-090	9.00	300	+0 / -0.04	3 (Wires inserted)	5
951-301-095	9.50	300	+0 / -0.04	3 (Wires inserted)	5
951-301-100	10.00	300	+0 / -0.04	3 (Wires inserted)	1
951-301-105	10.50	300	+0 / -0.04	3 (Wires inserted)	1
951-301-110	11.00	300	+0 / -0.04	3 (Wires inserted)	1
951-301-115	11.50	300	+0 / -0.04	3 (Wires inserted)	1
951-301-120	12.00	300	+0 / -0.04	3 (Wires inserted)	1



# Standard tubes

Copper / L 150 mm



Reference	Outside diameter (mm)	Length (mm)	Tolerance (mm)	Quantity / Package
951-312-001	0.15	150	+0 / -0.01	10
951-312-002	0.20	150	+0 / -0.01	10
951-312-003	0.30	150	+0 / -0.01	10
951-312-004	0.40	150	+0 / -0.01	10
951-312-005	0.50	150	+0 / -0.01	10
951-312-006	0.60	150	+0 / -0.02	10
951-312-007	0.70	150	+0 / -0.02	10
951-312-008	0.80	150	+0 / -0.02	10
951-312-009	0.90	150	+0 / -0.02	10
951-312-010	1.00	150	+0 / -0.02	10
951-312-011	1.10	150	+0 / -0.02	10
951-312-012	1.20	150	+0 / -0.02	10
951-312-013	1.30	150	+0 / -0.02	10
951-312-014	1.40	150	+0 / -0.02	10
951-312-015	1.50	150	+0 / -0.02	10
951-312-016	1.60	150	+0 / -0.02	10
951-312-017	1.70	150	+0 / -0.02	10
951-312-018	1.80	150	+0 / -0.02	10
951-312-019	1.90	150	+0 / -0.02	10
951-312-020	2.00	150	+0 / -0.02	10
951-312-021	2.10	150	+0 / -0.03	10
951-312-022	2.20	150	+0 / -0.03	10
951-312-023	2.30	150	+0 / -0.03	10
951-312-024	2.40	150	+0 / -0.03	10
951-312-025	2.50	150	+0 / -0.03	10
951-312-026	2.60	150	+0 / -0.03	10
951-312-027	2.70	150	+0 / -0.03	10
951-312-028	2.80	150	+0 / -0.03	10



# Standard tubes

Copper / L 150 mm

Reference	Outside diameter (mm)	Length (mm)	Tolerance (mm)	Quantity / Package
951-312-029	2.90	150	+0 / -0.03	10
951-312-030	3.00	150	+0 / -0.03	10
951-312-031	3.10	150	+0 / -0.03	10
951-312-032	3.20	150	+0 / -0.03	10
951-312-033	3.30	150	+0 / -0.03	10
951-312-034	3.40	150	+0 / -0.05	10
951-312-035	3.50	150	+0 / -0.05	10
951-312-036	3.60	150	+0 / -0.05	10
951-312-037	3.70	150	+0 / -0.05	10
951-312-038	3.80	150	+0 / -0.05	10
951-312-039	3.90	150	+0 / -0.05	10
951-312-040	4.00	150	+0 / -0.05	10
951-312-041	4.10	150	+0 / -0.05	10
951-312-042	4.20	150	+0 / -0.05	10
951-312-043	4.30	150	+0 / -0.05	10
951-312-044	4.40	150	+0 / -0.05	10
951-312-045	4.50	150	+0 / -0.05	10
951-312-046	4.60	150	+0 / -0.05	10
951-312-047	4.70	150	+0 / -0.05	10
951-312-048	4.80	150	+0 / -0.05	10
951-312-049	4.90	150	+0 / -0.05	10
951-312-050	5.00	150	+0 / -0.05	10
951-312-051	5.10	150	+0 / -0.05	10
951-312-052	5.20	150	+0 / -0.05	10
951-312-053	5.30	150	+0 / -0.05	10
951-312-054	5.40	150	+0 / -0.05	10
951-312-055	5.50	150	+0 / -0.05	10
951-312-056	5.60	150	+0 / -0.05	10
951-312-057	5.70	150	+0 / -0.05	10
951-312-058	5.80	150	+0 / -0.05	10
951-312-059	5.90	150	+0 / -0.05	10
951-312-060	6.00	150	+0 / -0.05	10
951-312-061	6.10	150	+0 / -0.15	10
951-312-062	6.20	150	+0 / -0.15	10
951-312-063	6.30	150	+0 / -0.15	10
951-312-064	6.40	150	+0 / -0.15	10
951-312-065	6.50	150	+0 / -0.15	10
951-312-066	6.60	150	+0 / -0.15	10
951-312-067	6.70	150	+0 / -0.15	10
951-312-068	6.80	150	+0 / -0.15	10
951-312-069	6.90	150	+0 / -0.15	10
951-312-070	7.00	150	+0 / -0.15	10



# Standard tubes

Copper / L 150 mm

Reference	Outside diameter (mm)	Length (mm)	Tolerance (mm)	Quantity / Package
951-312-071	7.10	150	+0 / -0.15	10
951-312-072	7.20	150	+0 / -0.15	10
951-312-073	7.30	150	+0 / -0.15	10
951-312-074	7.40	150	+0 / -0.15	10
951-312-075	7.50	150	+0 / -0.15	10
951-312-076	7.60	150	+0 / -0.15	10
951-312-077	7.70	150	+0 / -0.15	10
951-312-078	7.80	150	+0 / -0.15	10
951-312-079	7.90	150	+0 / -0.15	10
951-312-080	8.00	150	+0 / -0.15	10
951-312-081	8.10	150	+0 / -0.15	10
951-312-082	8.20	150	+0 / -0.15	10
951-312-083	8.30	150	+0 / -0.15	10
951-312-084	8.40	150	+0 / -0.15	10
951-312-085	8.50	150	+0 / -0.15	10
951-312-086	8.60	150	+0 / -0.15	10
951-312-087	8.70	150	+0 / -0.15	10
951-312-088	8.80	150	+0 / -0.15	10
951-312-089	8.90	150	+0 / -0.15	10
951-312-090	9.00	150	+0.1 / -0.2	10
951-312-095	9.50	150	+0.1 / -0.2	10
951-312-100	10.00	150	+0.1 / -0.2	10
951-312-105	10.50	150	+0.1 / -0.2	10
951-312-110	11.00	150	+0.1 / -0.2	10
951-312-120	12.00	150	+0.1 / -0.2	10
951-312-130	13.00	150	+0.1 / -0.2	10
951-312-140	14.00	150	+0.1 / -0.2	10
951-312-150	15.00	150	+0.1 / -0.2	10
951-312-160	16.00	150	+0.1 / -0.2	10
951-312-170	17.00	150	+0.1 / -0.2	10
951-312-180	18.00	150	+0.1 / -0.2	10
951-312-190	19.00	150	+0.1 / -0.2	10
951-312-200	20.00	150	+0.1 / -0.2	10



# Standard tubes

Copper / L 300 mm



Reference	Outside diameter (mm)	Length (mm)	Tolerance (mm)	Quantity / Package
951-313-001	0.15	300	+0 / -0.01	10
951-313-002	0.20	300	+0 / -0.01	10
951-313-003	0.30	300	+0 / -0.01	10
951-313-004	0.40	300	+0 / -0.01	10
951-313-005	0.50	300	+0 / -0.01	10
951-313-006	0.60	300	+0 / -0.02	10
951-313-007	0.70	300	+0 / -0.02	10
951-313-008	0.80	300	+0 / -0.02	10
951-313-009	0.90	300	+0 / -0.02	10
951-313-010	1.00	300	+0 / -0.02	10
951-313-011	1.10	300	+0 / -0.02	10
951-313-012	1.20	300	+0 / -0.02	10
951-313-013	1.30	300	+0 / -0.02	10
951-313-014	1.40	300	+0 / -0.02	10
951-313-015	1.50	300	+0 / -0.02	10
951-313-016	1.60	300	+0 / -0.02	10
951-313-017	1.70	300	+0 / -0.02	10
951-313-018	1.80	300	+0 / -0.02	10
951-313-019	1.90	300	+0 / -0.02	10
951-313-020	2.00	300	+0 / -0.02	10
951-313-021	2.10	300	+0 / -0.03	10
951-313-022	2.20	300	+0 / -0.03	10
951-313-023	2.30	300	+0 / -0.03	10
951-313-024	2.40	300	+0 / -0.03	10
951-313-025	2.50	300	+0 / -0.03	10
951-313-026	2.60	300	+0 / -0.03	10
951-313-027	2.70	300	+0 / -0.03	10
951-313-028	2.80	300	+0 / -0.03	10



# Standard tubes

Copper / L 300 mm

Reference	Outside diameter (mm)	Length (mm)	Tolerance (mm)	Quantity / Package
951-313-029	2.90	300	+0 / -0.03	10
951-313-030	3.00	300	+0 / -0.03	10
951-313-031	3.10	300	+0 / -0.05	10
951-313-032	3.20	300	+0 / -0.05	10
951-313-033	3.30	300	+0 / -0.05	10
951-313-034	3.40	300	+0 / -0.05	10
951-313-035	3.50	300	+0 / -0.05	10
951-313-036	3.60	300	+0 / -0.05	10
951-313-037	3.70	300	+0 / -0.05	10
951-313-038	3.80	300	+0 / -0.05	10
951-313-039	3.90	300	+0 / -0.05	10
951-313-040	4.00	300	+0 / -0.05	10
951-313-041	4.10	300	+0 / -0.05	10
951-313-042	4.20	300	+0 / -0.05	10
951-313-043	4.30	300	+0 / -0.05	10
951-313-044	4.40	300	+0 / -0.05	10
951-313-045	4.50	300	+0 / -0.05	10
951-313-046	4.60	300	+0 / -0.05	10
951-313-047	4.70	300	+0 / -0.05	10
951-313-048	4.80	300	+0 / -0.05	10
951-313-049	4.90	300	+0 / -0.05	10
951-313-050	5.00	300	+0 / -0.05	10
951-313-051	5.10	300	+0 / -0.05	10
951-313-052	5.20	300	+0 / -0.05	10
951-313-053	5.30	300	+0 / -0.05	10
951-313-054	5.40	300	+0 / -0.05	10
951-313-055	5.50	300	+0 / -0.05	10
951-313-056	5.60	300	+0 / -0.05	10
951-313-057	5.70	300	+0 / -0.05	10
951-313-058	5.80	300	+0 / -0.05	10
951-313-059	5.90	300	+0 / -0.05	10
951-313-060	6.00	300	+0 / -0.15	5
951-313-061	6.10	300	+0 / -0.15	5
951-313-062	6.20	300	+0 / -0.15	5
951-313-063	6.30	300	+0 / -0.15	5
951-313-064	6.40	300	+0 / -0.15	5
951-313-065	6.50	300	+0 / -0.15	5
951-313-066	6.60	300	+0 / -0.15	5
951-313-067	6.70	300	+0 / -0.15	5
951-313-068	6.80	300	+0 / -0.15	5
951-313-069	6.90	300	+0 / -0.15	5
951-313-070	7.00	300	+0 / -0.15	5



# Standard tubes

Copper / L 300 mm

Reference	Outside diameter (mm)	Length (mm)	Tolerance (mm)	Quantity / Package
951-313-071	7.10	300	+0 / -0.15	5
951-313-072	7.20	300	+0 / -0.15	5
951-313-073	7.30	300	+0 / -0.15	5
951-313-074	7.40	300	+0 / -0.15	5
951-313-075	7.50	300	+0 / -0.15	5
951-313-076	7.60	300	+0 / -0.15	5
951-313-077	7.70	300	+0 / -0.15	5
951-313-078	7.80	300	+0 / -0.15	5
951-313-079	7.90	300	+0 / -0.15	5
951-313-080	8.00	300	+0 / -0.15	5
951-313-090	9.00	300	+0.1 / -0.2	5
951-313-100	10.00	300	+0.1 / -0.2	1
951-313-110	11.00	300	+0.1 / -0.2	1
951-313-120	12.00	300	+0.1 / -0.2	1
951-313-130	13.00	300	+0.1 / -0.2	1
951-313-140	14.00	300	+0.1 / -0.2	1
951-313-150	15.00	300	+0.1 / -0.2	1
951-313-160	16.00	300	+0.1 / -0.2	1
951-313-170	17.00	300	+0.1 / -0.2	1
951-313-180	18.00	300	+0.1 / -0.2	1
951-313-190	19.00	300	+0.1 / -0.2	1
951-313-200	20.00	300	+0.1 / -0.2	1



# Standard tubes

Carbide / L 150 mm



Reference	Outside diameter (mm)	Length (mm)	Tolerance (mm)	Quantity / Package
951-316-001	0.38	150		10
951-316-002	0.46	150		10
951-316-003	0.51	150		10
951-316-004	0.56	150		10
951-316-005	0.64	150		10
951-316-006	0.76	150		10
951-316-007	0.91	150		10
951-316-008	0.99	150		10
951-316-009	1.09	150		10
951-316-010	1.19	150		10
951-316-011	1.35	150		10
951-316-012	1.145	150		10
951-316-013	1.60	150		10
951-316-014	1.70	150		10
951-316-015	1.80	150		10
951-316-016	1.88	150		10
951-316-017	1.96	150		10
951-316-018	2.03	150		10
951-316-019	2.13	150		10
951-316-020	2.26	150		10
951-316-021	2.39	150		10
951-316-022	2.51	150		10
951-316-023	2.59	150		10
951-316-024	2.77	150		10
951-316-025	2.87	150		10
951-316-026	2.97	150		10
951-316-027	3.10	150		10
951-316-028	3.18	150		10





# Standard tubes

Carbide / L 150 mm

Reference	Outside diameter (mm)	Length (mm)	Tolerance (mm)	Quantity / Package
951-316-029	3.58	150		10
951-316-030	3.96	150		10
951-316-031	4.37	150		10
951-316-032	4.67	150		10
951-316-033	5.16	150		10
951-316-034	5.56	150		10
951-316-035	5.94	150		10
951-316-036	6.27	150		10
951-316-037	6.35	150		10



# Standard tubes

Carbide / L 300 mm



Reference	Outside diameter (mm)	Length (mm)	Tolerance (mm)	Quantity / Package
951-317-001	0.127	300		10
951-317-002	0.152	300		10
951-317-003	0.178	300		10
951-317-004	0.203	300		10
951-317-005	0.229	300		10
951-317-006	0.254	300		10
951-317-007	0.279	300		10
951-317-008	0.305	300		10
951-317-009	0.33	300		10
951-317-010	0.356	300		10
951-317-011	0.381	300		10
951-317-012	0.406	300		10
951-317-013	0.432	300		10
951-317-014	0.457	300		10
951-317-015	0.483	300		10
951-317-016	0.508	300		10
951-317-017	0.559	300		10
951-317-018	0.61	300		10
951-317-019	0.66	300		10
951-317-020	0.711	300		10
951-317-021	0.762	300		10
951-317-022	0.813	300		10
951-317-023	0.864	300		10
951-317-024	0.914	300		10
951-317-025	0.965	300		10
951-317-026	1.016	300		10
951-317-027	1.143	300		10
951-317-028	1.27	300		10
951-317-029	1.397	300		10
951-317-030	1.524	300		10

# Start hole tube guides

Configuration recommendations with the 'non' insulated guide support plate

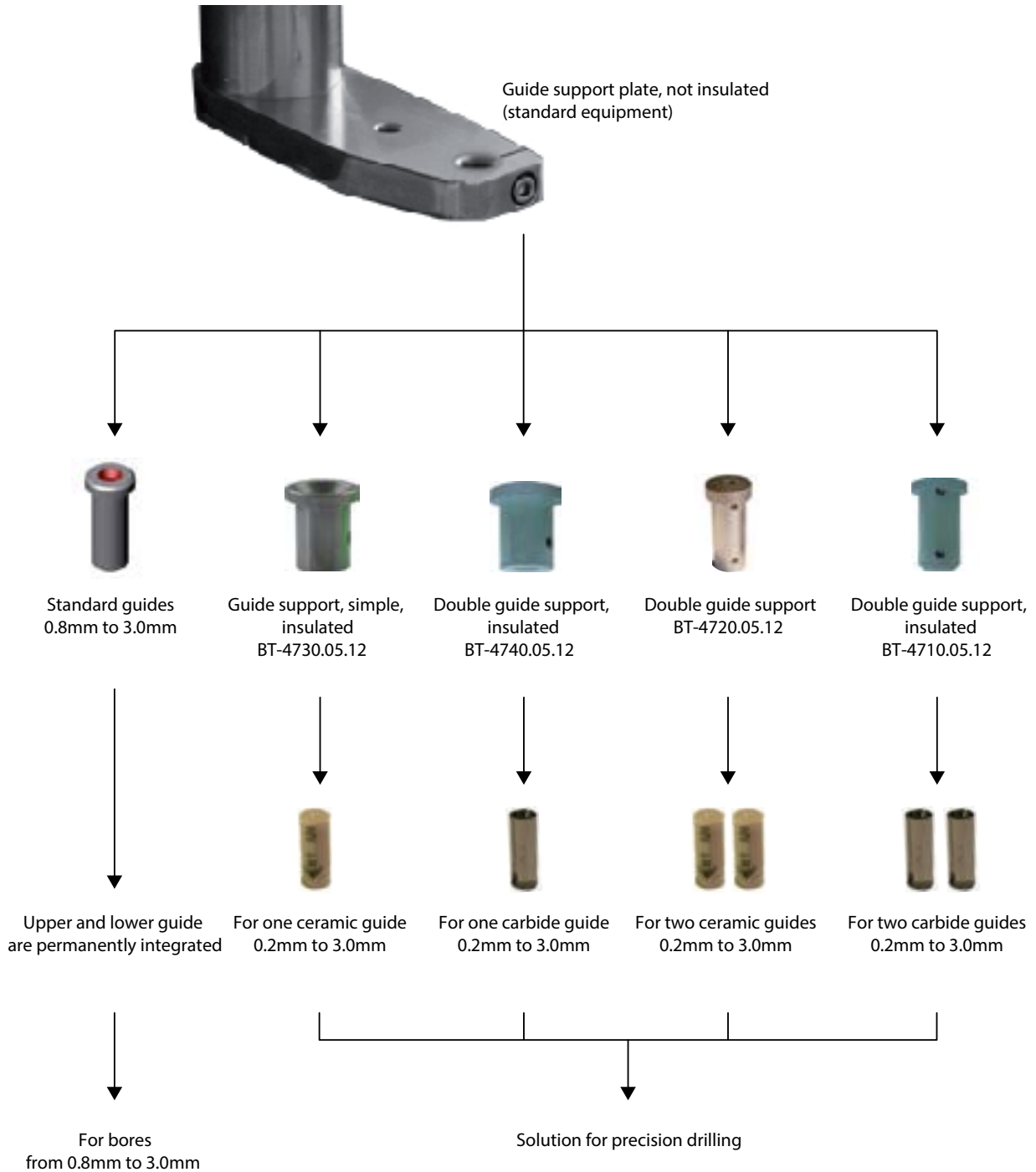

## Configuration recommendations with insulated guide support plate

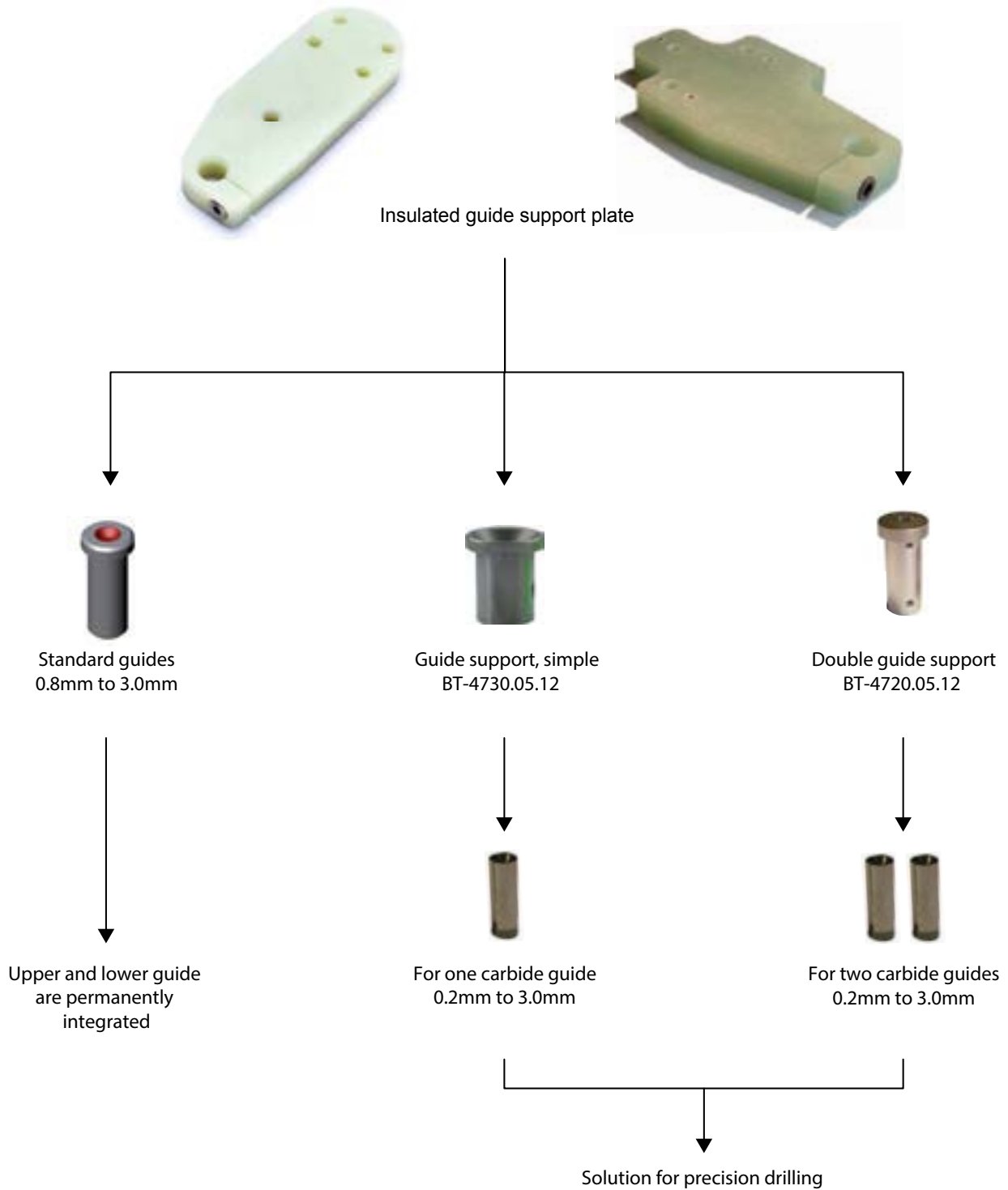

# Insulated guide support plate, adjustable



## CHARACTERISTIC

- + The insulated guide support plate allows the use of metal guides (without short-circuit risk)

Reference	Designation
-	Guide support plate, insulated for DRILL



## CHARACTERISTIC

- + The insulated guide support plate allows the use of metal guides (without short-circuit risk)

Reference	Designation
962-000-074	Guide support plate, insulated for DRILL

# Electrode support



Reference	Designation
BT-4800-06-11	Electrode support with carbide core $\varnothing$ 0.6 mm

# Guide support, simple insulated + not insulated



## CHARACTERISTIC

- + ATTENTION: Minimum distance between work-piece/guide support = 5 mm

Reference	Designation
BT-4730-05-12	Guide support, simple insulated + not insulated (n°1)
BT-4740-05-12	Guide support, simple insulated + insulated (n°2)

# Double guide support, insulated + not insulated



## CHARACTERISTIC

- + ATTENTION: Minimum distance between work-piece/guide support = 5 mm

Reference	Designation
BT-4720-05-12	Double guide support, insulated + not insulated (n°1)
BT-4710-05-12	Double guide support, insulated + insulated (n°2)

# Standard guides, single or kit



## CHARACTERISTIC

- + Any standard guide is supplied with a sealing ring
- + Other diameters on request

Reference	Designation
200-007-109	Standard guides, Ø 0.8mm
335-009-074	Standard guides, Ø 1.0mm
335-010-836	Standard guides, Ø 1.1mm
335-010-837	Standard guides, Ø 1.3mm
200-007-104	Standard guides, Ø 1.5mm
200-007-105	Standard guides, Ø 2.0mm
200-007-106	Standard guides, Ø 2.5mm
335-009-078	Standard guides, Ø 3.0mm
GF-388-015-391	Kit of 6 guides: Ø 1.0/1.1/1.2/1.3/1.4/1.5mm
GF-388-015-392	Kit of 6 guides: Ø 1.6/1.8/1.9/2.0/2.5/3.0mm
387-015-600	Adjustable chuck (n°1)
335-014-866	Sealing plug Ø 0.5 mm (n°2)
335-014-867	Sealing plug Ø 1 mm (n°2)
335-014-868	Sealing plug Ø 2 mm (n°2)
335-014-869	Sealing plug Ø 3 mm (n°2)



387-015-600



# Ceramic guide - precision guide



## CHARACTERISTIC

+ Other diameters on request

Reference	Designation
BT-4727-032-126	Ceramic guide - precision guide 0.3 mm
BT-4727-042-126	Ceramic guide - precision guide 0.4 mm
BT-4727-052-126	Ceramic guide - precision guide 0.5 mm
BT-4727-062-126	Ceramic guide - precision guide 0.6 mm
BT-4727-072-126	Ceramic guide - precision guide 0.7 mm
BT-4727-082-126	Ceramic guide - precision guide 0.8 mm
BT-4727-092-126	Ceramic guide - precision guide 0.9 mm
BT-4727-102-126	Ceramic guide - precision guide 1.0 mm
BT-4727-112-126	Ceramic guide - precision guide 1.1 mm
BT-4727-122-126	Ceramic guide - precision guide 1.2 mm
BT-4727-152-126	Ceramic guide - precision guide 1.5 mm
BT-4727-182-126	Ceramic guide - precision guide 1.8 mm
BT-4727-202-126	Ceramic guide - precision guide 2.0 mm
BT-4727-222-126	Ceramic guide - precision guide 2.2 mm
BT-4727-252-126	Ceramic guide - precision guide 2.5 mm
BT-4727-282-126	Ceramic guide - precision guide 2.8 mm
BT-4727-302-126	Ceramic guide - precision guide 3.0 mm

# Carbide guide – precision guide



## CHARACTERISTIC

+ Other diameters on request

Reference	Designation
BT-4507-032-14	Standard precision guide 0.3 mm
BT-4507-042-14	Standard precision guide 0.4 mm
BT-4507-052-14	Standard precision guide 0.5 mm
BT-4507-062-14	Standard precision guide 0.6 mm
BT-4507-072-14	Standard precision guide 0.7 mm
BT-4507-082-14	Standard precision guide 0.8 mm
BT-4507-092-14	Standard precision guide 0.9 mm
BT-4507-102-14	Standard precision guide 1.0 mm
BT-4507-112-14	Standard precision guide 1.1 mm
BT-4507-122-14	Standard precision guide 1.2 mm
BT-4507-152-14	Standard precision guide 1.5 mm
BT-4507-182-14	Standard precision guide 1.8 mm
BT-4507-202-14	Standard precision guide 2.0 mm
BT-4507-222-14	Standard precision guide 2.2 mm
BT-4507-252-14	Standard precision guide 2.5 mm
BT-4507-282-14	Standard precision guide 2.8 mm
BT-4507-302-14	Standard precision guide 3.0 mm



# Chemicals and Accessories



**Original**

high-end consumables line

# Content

Detergent Uveol	158
Detergent Easyclean	158
Detergent WIRASOL	159
Corrosion protection agent Uveol EWF	160
Corrosion protection agent AC 01	160
Anti-corrosion spray Antikor RS	161
Fixing Magnets	161
Digital conductivity meter	162
Digital conductivity meter ( $\mu\text{S}+\text{pH}$ )	162
Conductivity meter	163
Refractometer	163

# Detergent Uveol Det 7 SW



## CHARACTERISTIC

- + Please follow the instructions/dosage precisely
- + Do not discharge cleaning agent residues into the dielectric

Reference	Designation
962-000-072	Detergent Uveol plastic container 10 liters
962-000-070	Detergent Uveol plastic container 30 liters

# Detergent Easyclean



## CHARACTERISTIC

- + Easyclean cleaner can be used in the wire EDM process
- + Please follow the instructions/dosage precisely.
- + Do not discharge cleaning agent residues into the dielectric

Reference	Designation
962-000-017	Detergent Easyclean plastic container 10 liters

# Detergent WIRASOL



## CHARACTERISTIC

- + WIRASOL cleans and removes machining residues, rust and grease. WIRASOL is a hydrochloric acid-free product and is suitable for cleaning work-pieces, work locating fixtures and EDM machines. Do not allow cleaning agent residues to get into the dielectric (wire erosion water). For general cleaning add ½ to 1 liter of WIRASOL to a bucket full of water. Treat heavy deposits with undiluted WIRASOL. After cleaning, wash the parts with water and dry with a dry cloth

Reference	Designation
951-602-003	Detergent Wirasol plastic container 10 liters

# Corrosion protection agent Uveol EWF



## CHARACTERISTIC

- + Corrosion protection agent Uveol EWF has been specially developed for wire EDM equipments. It prevents, particularly on stainless workpieces, corrosion caused by the dielectric (deionized water)
- + Recommended quantity: 0.5%
- + Product classification according to Directive 1999/45/EG:
  - R38 – Skin irritation
  - R41 – Risk of serious eye damage
  - R51/53 – Toxic to aquatic organisms, may cause long-term adverse effects in the aquatic environment

Reference	Designation
962-000-071	Corrosion protection agent Uveol EWF (5 Liter)

# Corrosion protection agent AC 01



## CHARACTERISTIC

- + Corrosion protection agent AC 01 has been specially developed for wire EDM equipments. It prevents, particularly on stainless workpieces, corrosion caused by the dielectric (deionized water)
- + Anti-corrosion product AC 01 is non-toxic
- + Recommended quantity: 0.5% (+F machines ≤ 0.3%)

Reference	Designation
951-600-000	Corrosion protection agent AC 01 (3 Liter)
951-600-001	Corrosion protection agent AC 01 (5 Liter)
951-600-002	Corrosion protection agent AC 01 (10 Liter)



# Anti-corrosion spray Antikor RS



## CHARACTERISTIC

- + This product which was specially developed to meet wire-cutting EDM needs forms a protective film over the workpiece. It has no adverse effect on filters or exchange resins
- + Only spray the workpiece after positioning it because otherwise this can adversely affect the conductivity of the workpiece and result in positioning errors

Reference	Designation
951-601-001	Anti-corrosion spray Antikor RS, spray can 500 ml

# Fixing Magnets



## CHARACTERISTIC

- + Strength magnets for fixing of Drop-out parts: holding force 10Kg

Reference	Designation
951-700-000	Mini-Magnets set of 6 pieces

# Digital conductivity meter



## CHARACTERISTIC

- + Waterproof and robust
- + Wide display
- + Integrated temperature sensor for measurement or temperature compensation
- + Easily replaceable electrode
- + Automatic calibration via the keyboard
- + Automatic temperature compensation
- + Stability indicator for reliable measurement results
- + HOLD function to freeze a measured value on the display
- + Adjustable TDS factor and temperature coefficient
- + Automatic shutdown after 8 minutes of measuring pause (saves batteries)

Reference	Designation
962-000-075	Digital conductivity meter

# Digital conductivity meter ( $\mu\text{S}+\text{pH}$ )



## CHARACTERISTIC

- + Waterproof and robust
- + Wide dual display
- + Integrated temperature sensor for measurement or temperature compensation
- + Easily replaceable electrode
- + Automatic calibration via the keyboard
- + Automatic temperature compensation
- + Stability indicator for reliable measurement results
- + HOLD function to freeze a measured value on the display
- + Adjustable TDS factor and temperature coefficient
- + Automatic shutdown after 8 minutes of measuring pause (saves batteries)

Reference	Designation
962-000-076	Digital conductivity meter

# Conductivity meter



## CHARACTERISTIC

- + The conductivity meter allows a quick check of the conductance of the machine and of the fresh water. It also has a temperature display

Reference	Designation
873-693-200	Digital conductivity meter

# Refractometer



## CHARACTERISTIC

- + The refractometer is used to measure the mixing ratio between the water and the additive (for example rust inhibitor)

Reference	Designation
873-678-500	Refractometer

# Information

## Original and Compliant product ranges

GF consumables have been divided in two products series: Original and Compliant. Both categories are served through the same channel and are covered by the same warranty but delivered at a different level of quality.

The Compliant product line has been created in order to meet customers' needs whenever an application requires high cost-effectiveness. In all other cases we recommend to opt for our Original products in order to obtain better performances and benefits from all our know-how which is embodied in our Original products.

## Original

high-end consumables line

### High-end product line for GF machines

- + Highest quality (mainly made in EU)
- + Specifically for GF machines (homologated)
- + Full application support

## Compliant

entry-level consumables line

### Entry-level product line for GF machines

- + Good quality (mainly made in Asia)
- + Compatible with GF machines (tested)

## Electronic version of the catalog

This catalog is also available in digital format and can be downloaded from GF Machining Solutions Website [www.gfms.com/ch](http://www.gfms.com/ch). The PDF version is always up-to-date and represents the latest version available: you may find discrepancies between the printed and the digital version and some products may have been removed or added.

## Product specification sheets and safety documentation

All the documentation containing product specifications and safety norms concerning the products presented in this catalog is available for download on our website. Please check [www.gfms.com/ch](http://www.gfms.com/ch) for more information.



# Contact

## Orders

For all your orders for consumables please contact our sales administration:

Tel +41 (0)91 806 92 20

Fax +41 (0)91 806 90 49

[consumables.ch@georgfischer.com](mailto:consumables.ch@georgfischer.com)

## Product information

For general questions about products and requests for quotes, please contact our Product Management:

Roberto Baccalà

Tel +41 (0)91 806 93 75

Fax +41 (0)860 79 681 42 31

[roberto.baccala@georgfischer.com](mailto:roberto.baccala@georgfischer.com)





Version: RES EN 1.2

Print: March 2015

© 2015 GF Machining Solutions International SA

## GF Machining Solutions



### Milling

**High-speed and High-performance Milling Centers.** In terms of cutting speed, HSM centers are 10 times faster than conventional milling machines. Greater accuracy and a better surface finish are also achieved. This means that even tempered materials can be machined to a condition where they are largely ready to use. One essential advantage of HSM is that with systematic integration, the process chain can be significantly shortened. HSM has developed alongside EDM into one of the key technologies in mold and tool making.



### EDM

**Electric Discharge Machines.** EDM can be used to machine conductive materials of any hardness (for example steel or titanium) to an accuracy of up to one-thousandth of a millimeter with no mechanical action. By virtue of these properties, EDM is one of the key technologies in mold and tool making. There are two distinct processes – wire-cutting EDM and die-sinking EDM.



### Laser

**Laser texturing.** Laser texturing supplements and extends the technologies offered by GF Machining Solutions. With our laser technology we enable you to produce texturing, engraving, microstructuring, marking and labeling of 2D geometries right through to complex 3D geometries. Laser texturing, compared to conventional surface treatment using manual etching processes, offers economic, ecological and design advantages.



### Automation

**Tooling, Automation, Software.** Tooling for fixing workpieces and tools; automation systems and system software for configuring machine tools and recording and exchanging data with the various system components and design advantages.



### Customer Services

**Operations, Machine and Business Support.** Customer Services provides three levels of support for all kinds of services for GF Machining Solutions.

Operations Support offers the complete range of original wearing parts and certified consumables including wires, filters, electrodes, resin and many other materials.

Machine Support includes all services relating to spare parts, technical support and preventive servicing. Business Support offers business solutions tailored to suit the customer's specific needs.





## Contact

GF Machining Solutions International SA  
via dei Pioppi 2  
6616 Losone  
Schweiz  
Tel +41 (0)91 806 90 30  
Fax +41 (0)91 806 90 33  
Email: [info.gfms.ch@georgfischer.com](mailto:info.gfms.ch@georgfischer.com)  
[www.gfms.com/ch](http://www.gfms.com/ch)



© 2015 GF Machining Solutions International SA  
Technical data and illustrations are not binding.  
They are all not guaranteed features and are subject to change.

