

System 3R

Transformer Concept with six-axis robot



**Tailored to serve
your needs**

Contents

Scalable Automation	4
Customer-specific Solutions	6
Standardized modules	8
WSM – WorkShopManager	10
Customer Services	12
Technical specifications	14
GF Machining Solutions	18



System 3R offer automation solutions with industrial robots, both stationary and rail versions within the Die & Mold and Precision Production sector.

The 6-axis robot solution covers applications in terms of ...

- ... transfer weight from 70-700 kg
- ... radial reach, up to 3 400 mm
- ... complexed transfer movements
- ... parts handling

- Whatever the Automation requirement, the 6-axis robot solution can be tailored to serve your needs: customer-specific solutions.
- Modern technology & smart technical solutions using standardized modules allow for cost-effective yet flexible Automation
- User-friendly cell management software: complex Automation made easy!
- Everything from your single source supplier: GF Machining Solutions

Achieve greater return on your investment !

Scalable Automation – System 3R

Grows with your needs

Begin with a single machine and small magazine capacity.

Begin

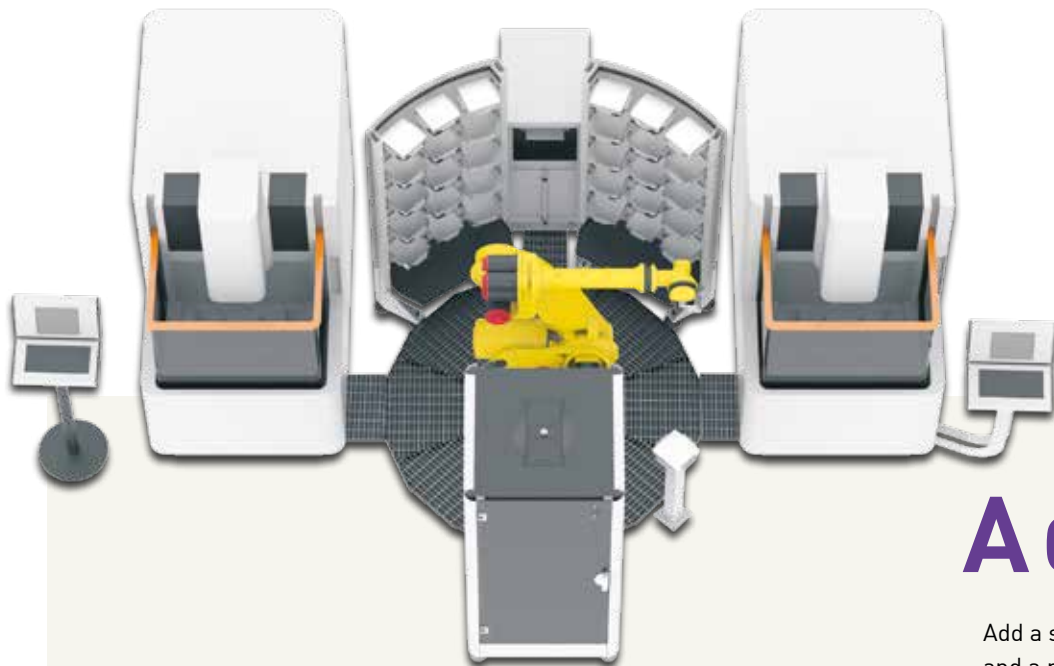
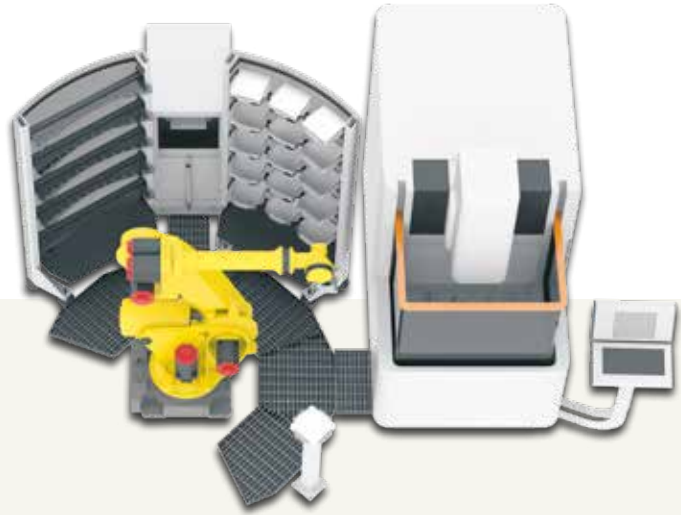

Add

Add a second machine and a rotary magazine for more capacity.

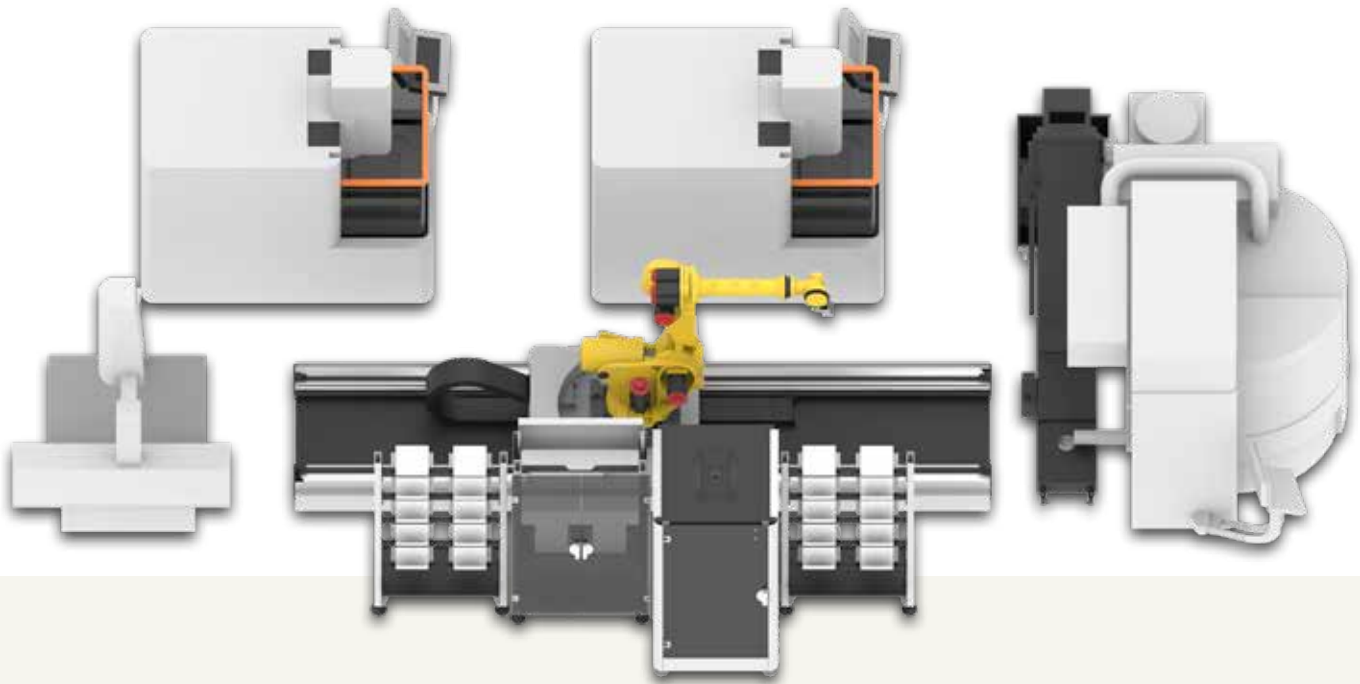

Place the robot on rails and add magazine capacity to serve additional machines, or start with a similar solution from the beginning.

E X T E N D

Customer-specific Solutions

Tailored to serve your needs

Milling application

Model 360 – Stationary robot
Milling machine
Rack magazines
Loading/index station



Milling application

Model 360 on rail
Three Milling machines
Washing machine
Rack magazines
Loading/index station





Milling application

Model 700 – Stationary robot

Milling machine

Rack magazines

Loading/index station

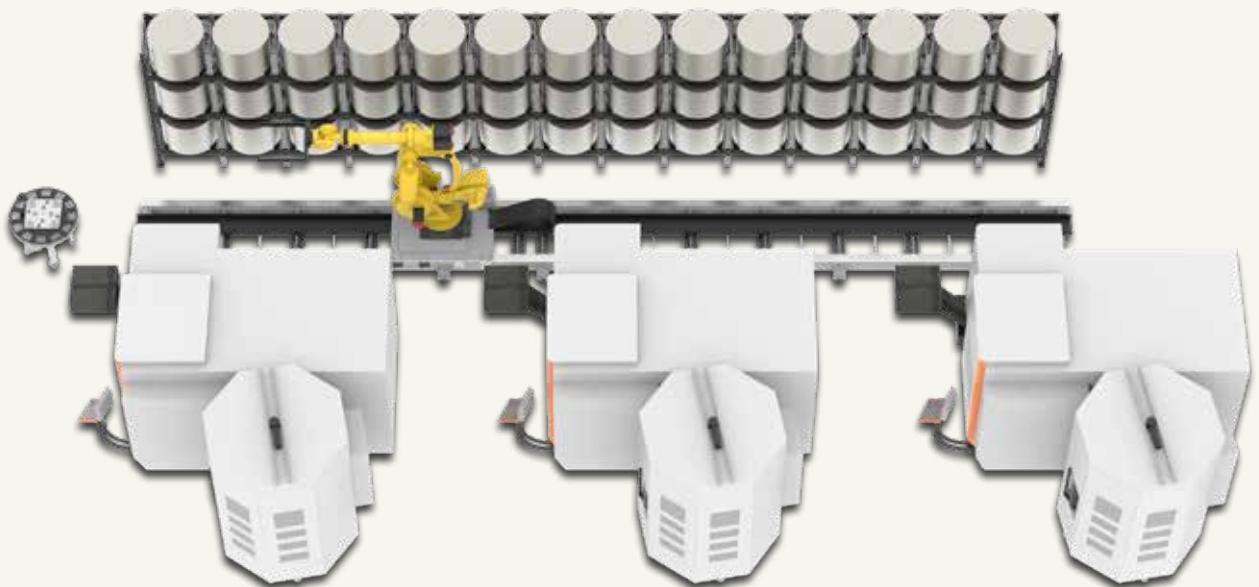

Milling application

Model 700 on rail

Three Milling machines

Rack magazines

Loading/index station



Standardized modules

For cost-effective solutions

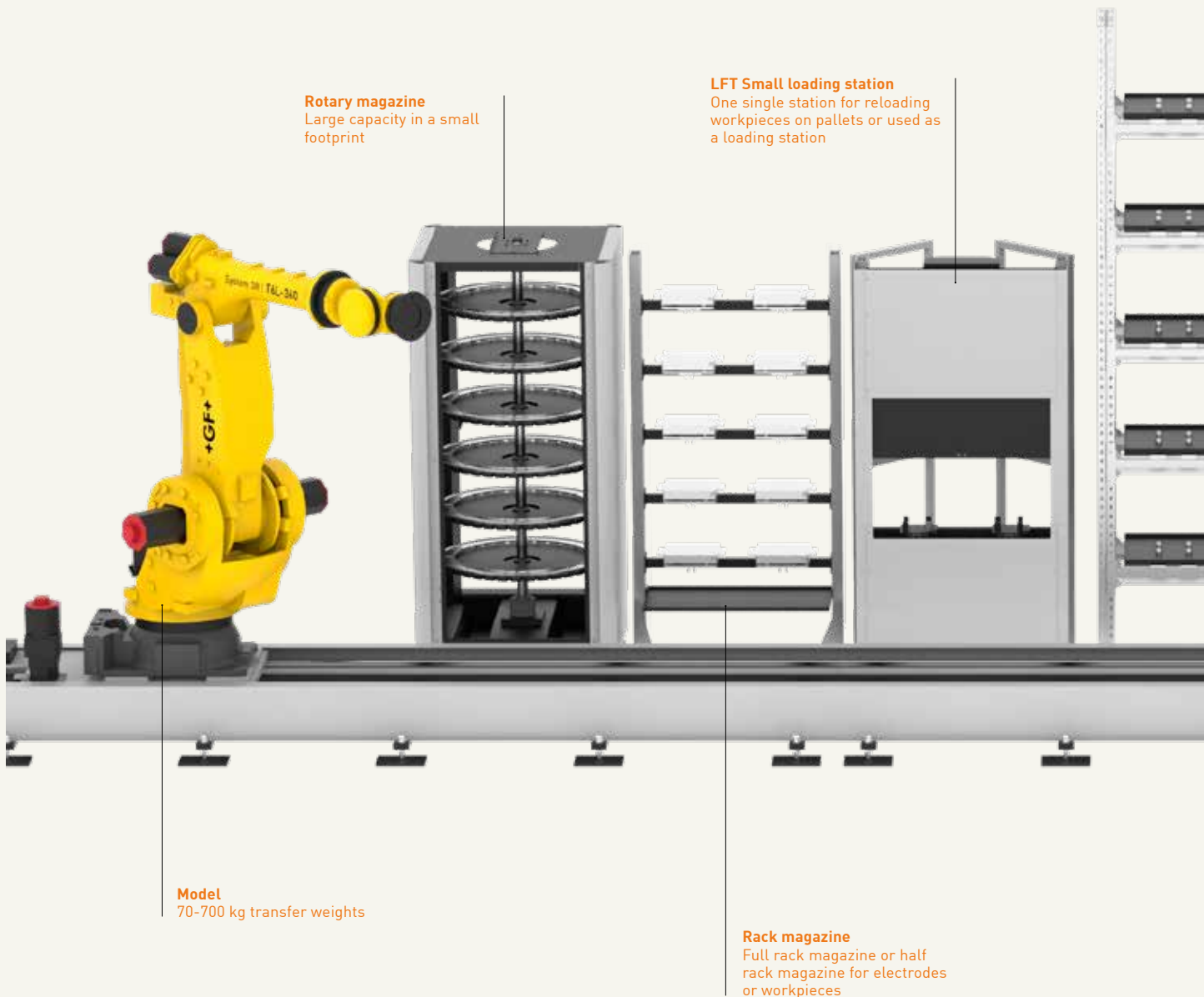

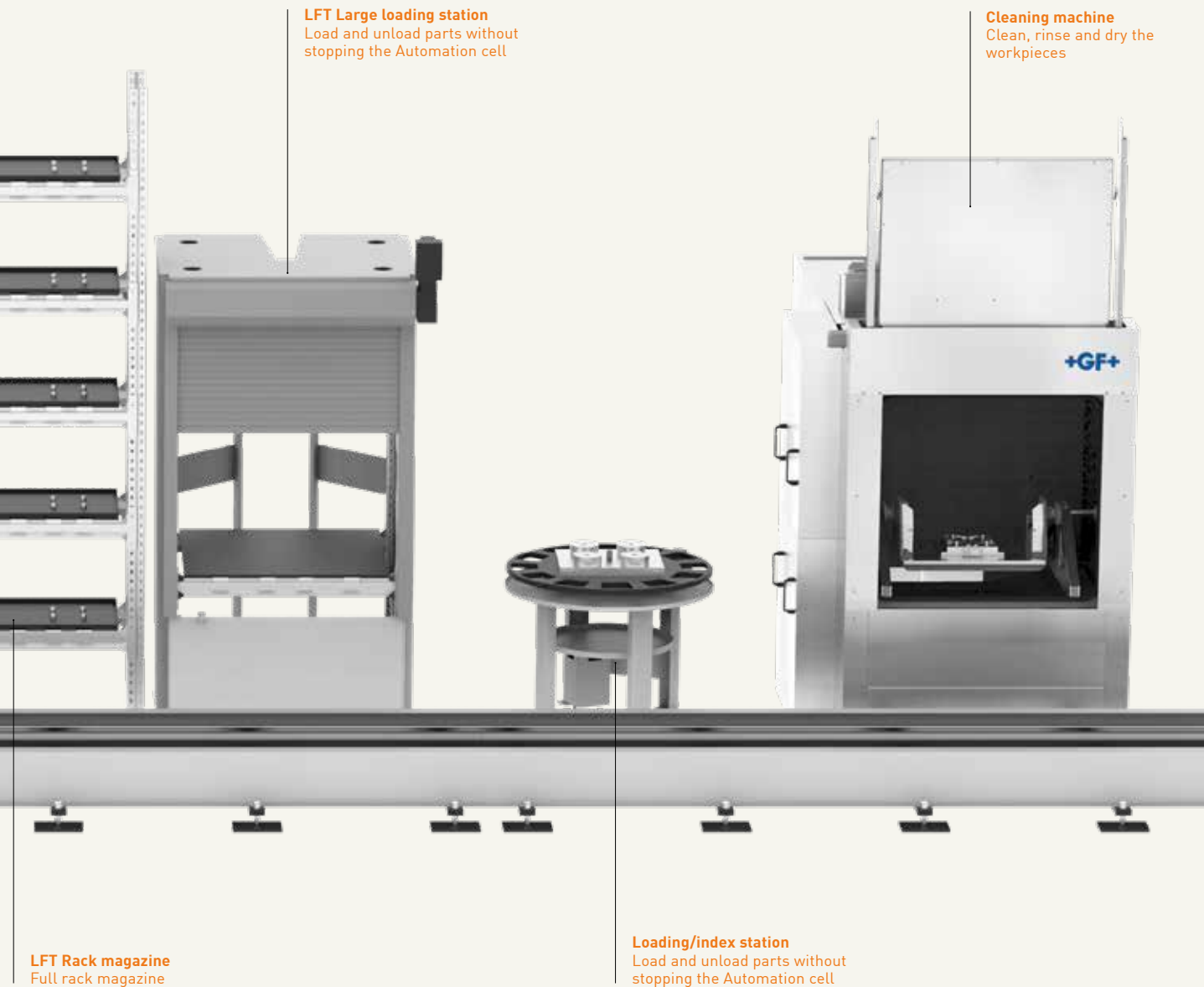

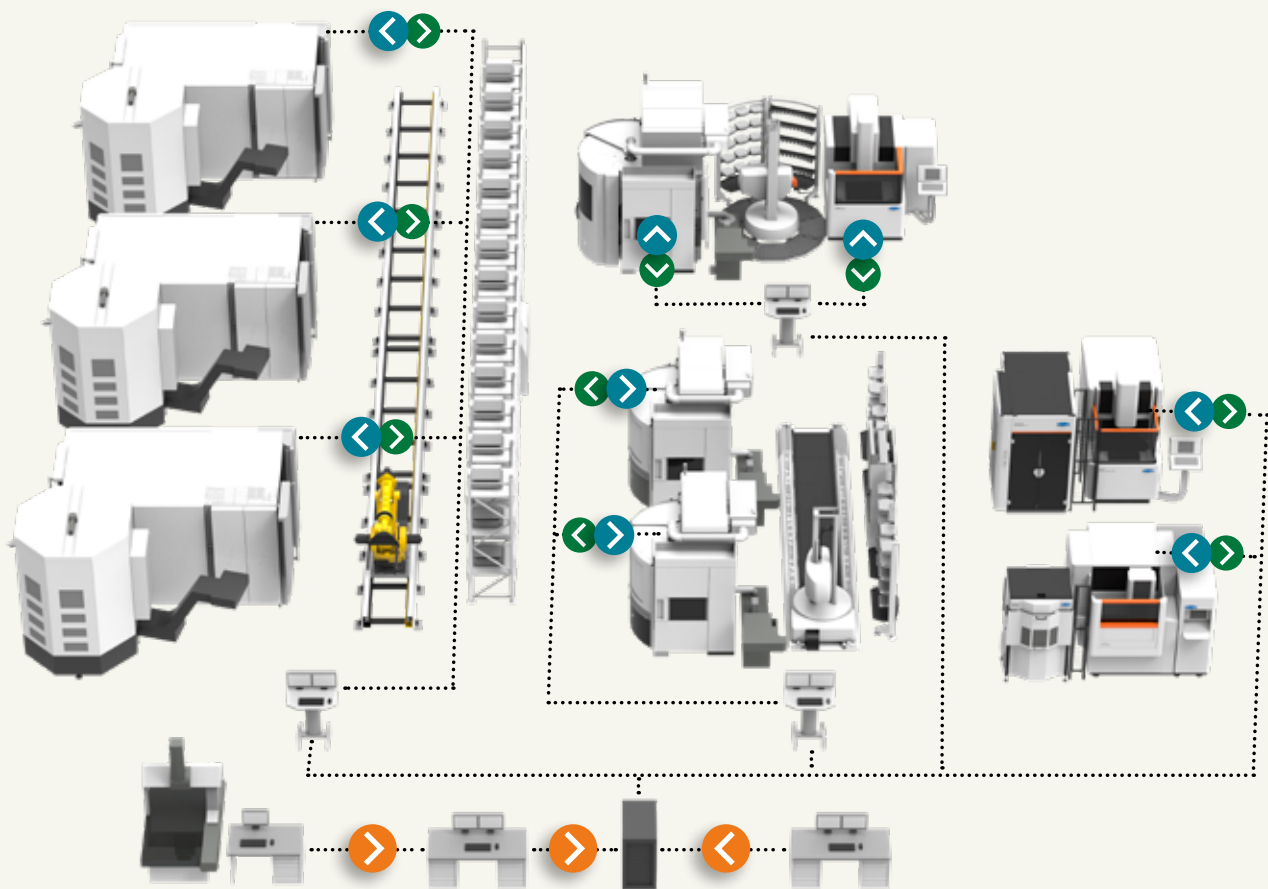

WSM – WorkShopManager

User-friendly Cell Management Software

- Necessary data is entered quickly and in a structured manner.
- Quick, precise overview of the entire process chain
- Increased flexibility: The order of priority can be changed at any time.
- Simpler, safer preparation of automated cells
- The risk of errors due to the human factor is minimized.
- Increased process security



.....> **Preparation – WorkCenter**

- Create an order
- Assign operations and NC programs
- Retrieve offset values
- Release the order for production

.....> **Monitoring – CellMonitor**

- Display status of all cells
- Display status of individual machines and processes

Statistics – WSM Statistics

- Retrieve and analyze cell utilization data
- Retrieve and analyze order data

.....> **Execution – CellManager**

- Manages the pallet ID codes and magazine positions
- Creates priority lists
- Automatically starts available jobs in the order of the priority list
- Updates the information in the database with the status and machining times of individual orders

Customer Services

Optimize the uptime of your equipment with our Machine Support services

Annual reconditioning minimizes production stops and optimizes function, precision and performance. GF Machining Solutions offers comprehensive services for your Automation, reference systems and masters and calibration tools.

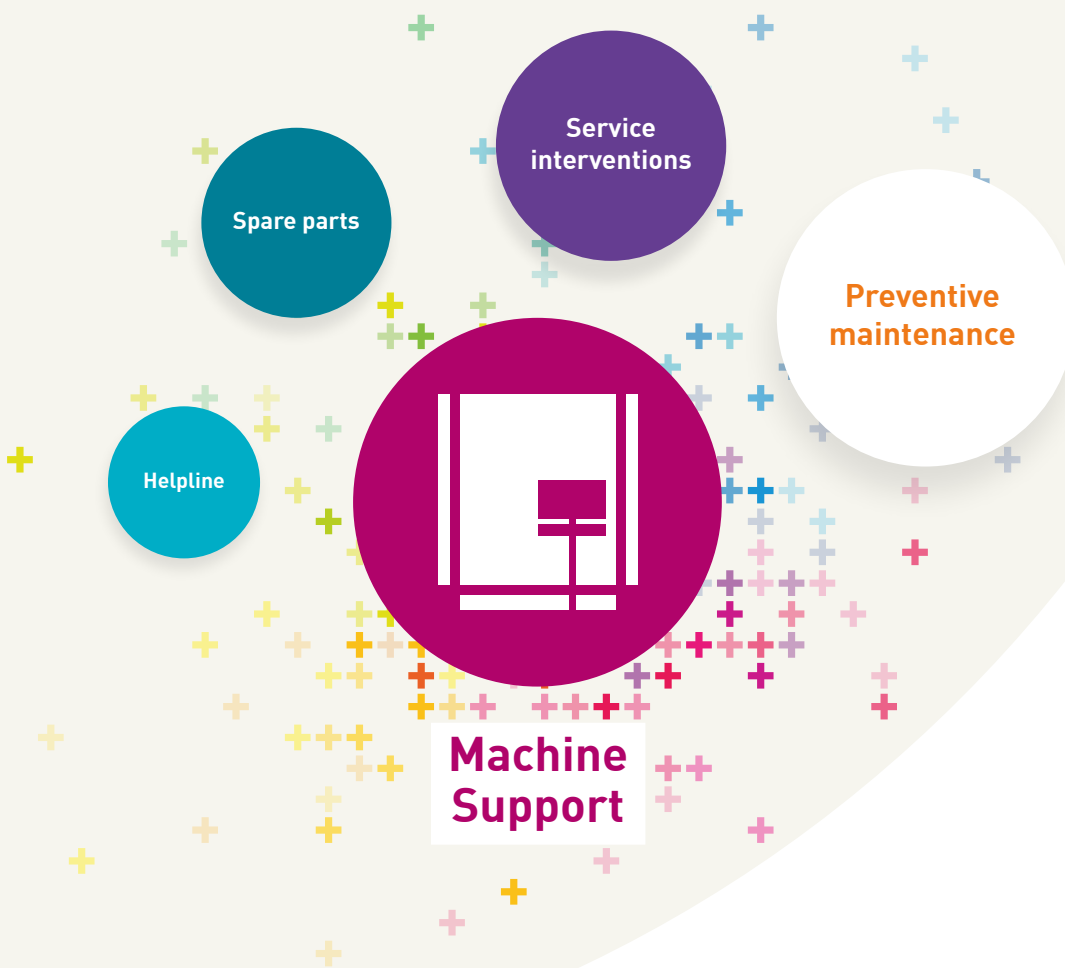

Preventive maintenance

Automation

- Mechanics
- Pneumatics
- Peripheral equipment



Reference systems

- Rebuilding chucks
- Inspecting references
- Checking clamping force



Masters and calibration tools

- Cleaning and polishing
- CMM inspection
- Quality certificate



CE Certification

GF Machining Solutions' Customer Services also offers CE Certification of Conformity for complete Automation cells.

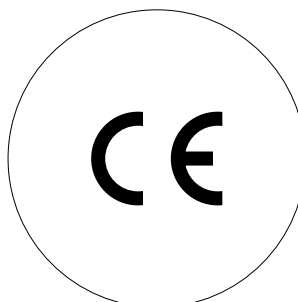

Technical specifications

Six-axis robots

Robot Model
70/165/210/360/700



Robot model on rail
70/165/210/360/700



	Robot Model 70/165/210/360/700	Robot model on rail 70/165/210/360/700
Payload	70, 165, 210, 360, 700 kg. 155, 366, 466, 800, 1555 lbs	
Max. X-reach	70 kg = 2050 mm, 165-360 kg = 2655 mm, 700 kg = 2832 mm 70 kg = 80.7 in, 165-360 kg = 104.5 in, 700 kg = 111.5 in	
Max. Z-reach	1400 mm 55.12 in	
Max. C-rotation	360-370°	
Stationary cell, max. # of machines	Up to 3	
Linear cell, max. # of machines	Up to 12	
Rail type	Standard Heavy	
Max. rail length	Standard 20 m, 787 in Heavy 30 m, 1181 in	
Max. transfer weight (pallet and workpiece)	70 kg, 155 lbs (Model 70) 165 kg, 366 lbs (Model 165) 210 kg, 466 lbs (Model 210) 360 kg, 800 lbs (Model 360) 700 kg, 1555 lbs (Model 700)	

Accessories

LFT half rack magazine, max pallet size	850 x 550 mm (33.5 x 21.6 in)
LFT full rack magazine, max pallet size	850 x 800 mm (33.5 x 31.5 in)
Half rack magazine, max pallet size	480 x 400 mm (18.9 x 15.7 in)
Full rack magazine, max pallet size	700 x 450 mm (27.6 x 17.7 in)
Rotary magazine, max. pallet size	320 x 320 mm (12.6 x 12.6 in)
Multiple loading station	Depending on tooling and number of positions
LFT loading station	850 x 800 mm (33.5 x 31.6 in)
Loading station	max. 200 kg (440 lbs), 450 x 450 mm (17.71 x 17.71 in)
Loading/index station	570 x 570 mm (22.4 x 22.4 in)
Cleaning machine	max. 200 kg (440 lbs), 500 x 500 mm (19.68 x 19.68 in)



Rail type

Standard (only for 70, 165 and 210 models)

Heavy

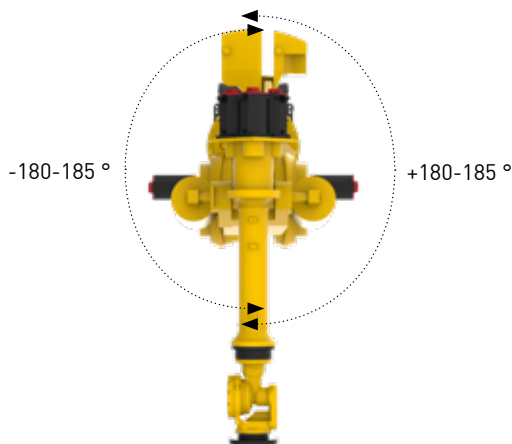
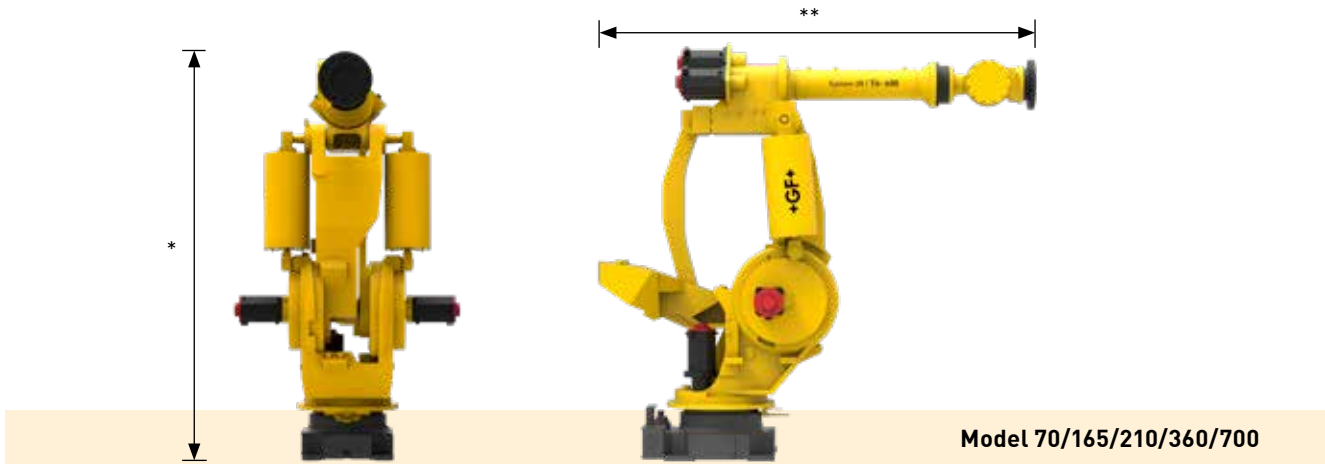

*** Depending on model/type**

- Model 70 = 1757 mm (69 in)
- Model 165 = 2081 mm (82 in)
- Model 210 = 2115 mm (83 in)
- Model 360 = 2285 mm (90 in)
- Model 700 = 2565 mm (101 in)

**** Depending on model/type**

- Model 70 = 1717 mm (67.6 in)
- Model 165 = 2322 mm (82 in)
- Model 210 = 2387 mm (91 in)
- Model 360 = 2415 mm (95 in)
- Model 700 = 2810 mm (110.6 in)

Model 70

Reach capacity: 2050 mm, 80.7 in.
C-Rotation: 360°

Model 165

Reach capacity: 2655 mm, 104.5 in.
C-Rotation: 370°

Model 210

Reach capacity: 2655 mm, 104.5 in.
C-Rotation: 370°

Model 360

Reach capacity: 2655 mm, 104.5 in.
C-Rotation: 360°

Model 700

Reach capacity: 2832 mm, 111.4 in.
C-Rotation: 360°

Robot rail

Max robot travel, Standard: 20 m (787 in)
Max robot travel, Heavy: 30 m (1181 in)

Max number of machines

Stationary cell: 3
Linear cell: 12

Technical specifications

Magazines



Rotary



LFT half rack



LFT full rack



Half rack



Full rack

Magazines are available in two basic designs: rack and rotary.

Each magazine unit consists of a number of shelves (determined by the height of the workpieces in question).

Rotary magazine

Tooling*	Pos.**	Size in mm (in)
Dynafix	4	320 x 320 (12.6 x 12.6)
	5	290 x 290 (11.4 x 11.4)
GPS 240	4	320 x 320 (12.6 x 12.6)
	5	290 x 290 (11.4 x 11.4)
	6	260 x 260 (10.2 x 10.2)
Macro-Magnum	8	210 x 210 (8.27 x 8.27)
	10	185 x 185 (7.28 x 7.28)
	12	160 x 160 (6.3 x 6.3)
GPS 120	12	160 x 160 (6.3 x 6.3)
Macro	36	65 x 65 (2.56 x 2.56)

Option

Rapid ID scanning

Full rack magazine

Tooling*	Pos.**	Size in mm (in)
Macro	12	70 x 200 (2.75 x 12.2)
Macro 116	6	150 x 150 (5.9 x 5.9)
Macro-Magnum	4	210 x 210 (8.27 x 8.27)
Dynafix	5	170 x 170 (6.7 x 6.7)
	2	400 x 400 (15.75 x 15.75)
GPS 70	1	700 x 500 (27.56 x 19.68)
	10	95 x 95 (3.74 x 3.74)
GPS 240	3	275 x 275 (10.83 x 10.83)
	2	400 x 400 (15.75 x 15.75)
Delphin	2	400 x 400 (15.75 x 15.75)
	1	700 x 500 (27.56 x 19.68)

Half rack magazine

Tooling*	Pos.**	Size in mm (in)
Dynafix	1	480 x 400 (18.9 x 15.75)
GPS 240	1	480 x 400 (18.9 x 15.75)
Delphin	1	480 x 400 (18.9 x 15.75)
400 x 400		

Options

Additional shelves
Door for loading from behind

LFT Full rack magazine

Tooling*	Pos.**	Size in mm (in)
Dynafix	1	850 x 800 (33.4 x 31.5)
	2	400 x 800 (15.7 x 31.5)
GPS 240	1	850 x 800 (33.4 x 31.5)
	2	400 x 800 (15.7 x 31.5)
Delphin	1	850 x 800 (33.4 x 31.5)
	2	400 x 800 (15.7 x 31.5)

LFT half rack magazine

Tooling*	Pos.**	Size in mm (in)
Dynafix	1	850 x 550 (33.4 x 21.6)
	2	500 x 500 (19.7 x 19.7)
GPS 240	1	850 x 550 (33.4 x 21.6)
	2	500 x 500 (19.7 x 19.7)
Delphin	1	850 x 550 (33.4 x 21.6)
	2	500 x 500 (19.7 x 19.7)

* Other tooling upon request

** Positions per level
Note: The maximum height of the workpiece depends on the number of levels

Technical specifications

Accessories



Multiple loading station



LFT loading station

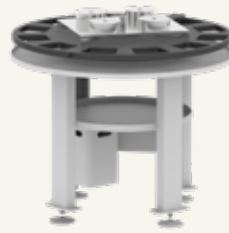

Loading/index station

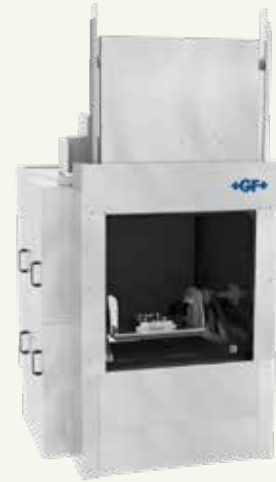

Cleaning machine

Multiple loading station & LFT Loading station

Used for loading and unloading without the need to stop the Automation cell

The station is equipped with ID antennas and presence sensors.

It can be configured to meet the requirements of tooling type and part sizes.

Loading/index Station

Used for preparing the workpieces with a indexing table.

Max. workpiece size, round: dia. 800 mm (31.5 in)

Max. workpiece size, square: 570 x 570 mm (22.4 x 22.4 in)

Max. load: 500 kg (1111 lbs)

Load or work preparation area for all standard tooling

Indexable every 30°

Collecting tray for oil & flushing liquid

Presence detection

Cleaning machine

A washing machine intended for cleaning, rinsing and air drying metal components placed on a pallet.

The unit consists of an insulated cabinet with a lifting door, fixed spraying system and a rotating fixture for the pallets. The unit is automatically loaded by the robot.

Maximum part size

500 x 500 x 500 mm (19,7 x 19,7 x 19,7 in)

including pallet, chuck and workpiece

Maximum weight

200 kg (440 lbs) including pallet, chuck and workpiece

GF Machining Solutions



Milling

High-Speed and High-Performance Milling Centers. In terms of cutting speed, HSM centers are 10 times faster than conventional milling machines. Greater accuracy and a better surface finish are also achieved. This means that even tempered materials can be machined to a condition where they are largely ready to use. One essential advantage of HSM is that with systematic integration, the process chain can be significantly shortened. HSM has developed alongside EDM into one of the key technologies in mold and tool making.



EDM

Electric Discharge Machines. EDM can be used to machine conductive materials of any hardness (for example steel or titanium) to an accuracy of up to one-thousandth of a millimeter with no mechanical action. By virtue of these properties, EDM is one of the key technologies in mold and tool making. There are two distinct processes — wire-cutting EDM and die-sinking EDM.



Laser

Laser texturing. Laser texturing supplements and extends the technologies offered by GF Machining Solutions. With our laser technology we enable you to produce texturizing, engraving, microstructuring, marking and labeling of 2D geometries right through to complex 3D geometries. Laser texturing, compared to conventional surface treatment using manual etching processes, offers economic, ecological and design advantages.



Automation

Tooling, Automation, Software. Tooling for fixing workpieces and tools; automation systems and system software for configuring machine tools and recording and exchanging data with the various system components and design advantages.



Customer Services

Operations, Machine and Business Support. Customer Services provides with three levels of support all kind of services for GF Machining Solutions machines. Operations Support offers the complete range of original wear parts and certified consumables including wires, filters, electrodes, resin and many other materials. Machine Support contains all services connected with spare parts, technical support and preventive services. Business Support offers business solutions tailored to the customer's specific needs.

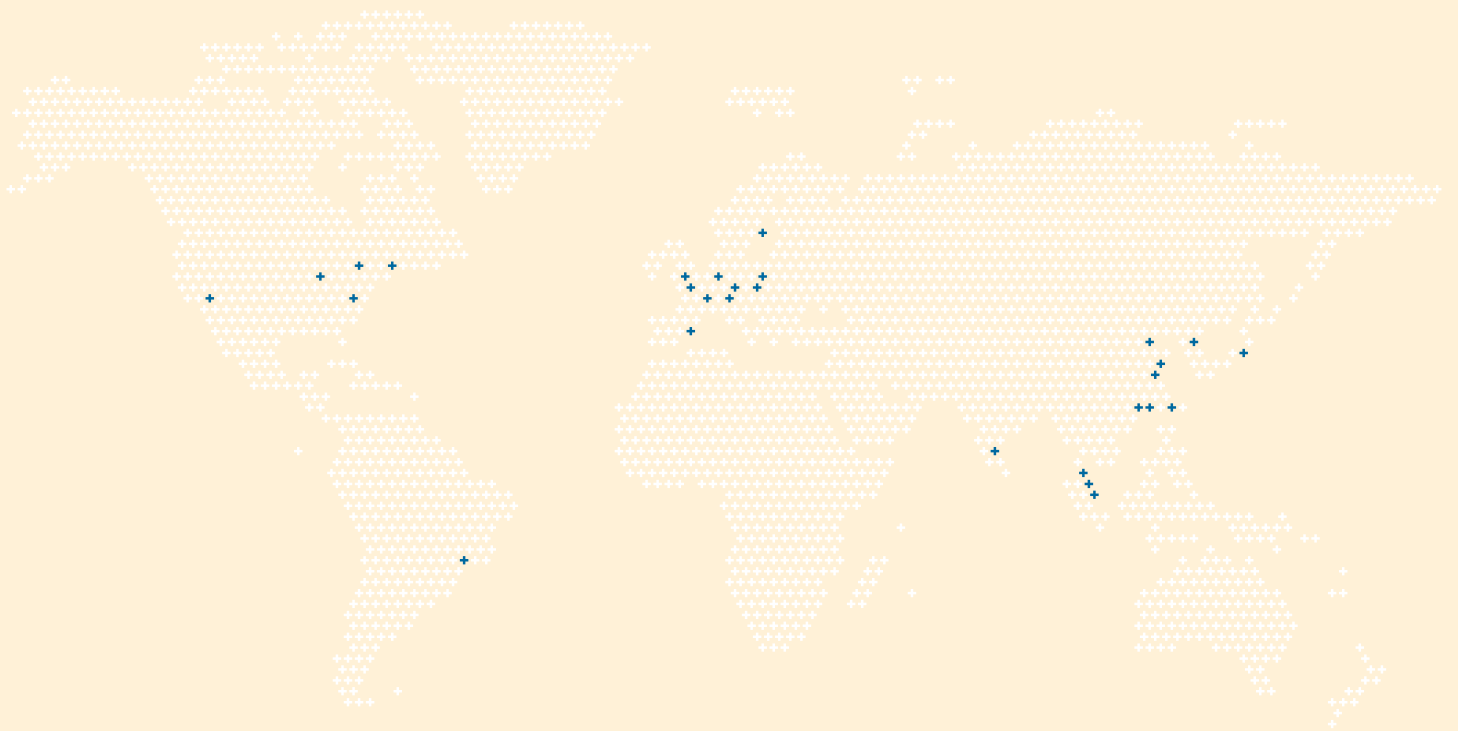

At a glance

We enable our customers to run their businesses efficiently and effectively by offering innovative Milling, EDM, Laser and Automation solutions. A comprehensive package of Customer Services completes our proposition.

www.gfms.com

